



**Luftheizgeräte
Air Heaters
Luchtverwarmingsapparaten**

**Einbauanweisung
Installation Instructions
Montagehandleiding**

Air Top 2000 STC

Handelsbezeichnungen/Trade names/Handelsnamen:

Air Top 2000 STC B (Benzin/petrol/benzine)

Air Top 2000 STC D (Diesel/FAME)



Das unsachgemäße Einbauen oder Reparieren von Webasto Heiz- und Kühlsystemen kann Feuer verursachen oder zum Austritt von tödlichem Kohlenmonoxid führen. Dadurch können schwere oder tödliche Verletzungen hervorgerufen werden.

Für den Einbau und die Reparatur von Webasto Heiz- und Kühlsystemen bedarf es eines Webastotrainings, technischer Dokumentation, Spezialwerkzeuge und einer Spezialausrüstung.

Es dürfen nur Originalteile von Webasto verwendet werden. Siehe dazu auch Zubehörkatalog Luft- und Wasserheizgeräte von Webasto.



Versuchen Sie NIEMALS, Webasto Heiz- oder Kühlsysteme einzubauen oder zu reparieren, wenn Sie das Webasto-training nicht erfolgreich abgeschlossen und dabei die notwendigen technischen Fähigkeiten erworben haben und die für einen sachgerechten Einbau und Reparatur nötigen technischen Dokumentationen, Werkzeuge und Ausrüstungen nicht zur Verfügung stehen.

Befolgen Sie IMMER alle Webasto Einbau- und Reparaturanleitungen, und beachten Sie alle Warnhinweise.

Webasto übernimmt keine Haftung für Mängel und Schäden, die auf einen Einbau durch ungeschultes Personal zurückzuführen sind.



Improper installation or repair of Webasto heating and cooling systems can cause fire or the leakage of deadly carbon monoxide leading to serious injury or death.

To install and repair Webasto heating and cooling systems you need to have completed a Webasto training course and have the appropriate technical documentation, special tools and special equipment.

Only genuine Webasto parts may be used. See also Webasto air and water heaters accessories catalogue.

NEVER try to install or repair Webasto heating or cooling systems if you have not completed a Webasto training course, you do not have the necessary technical skills and you do not have the technical documentation, tools and equipment available to ensure that you can complete the installation and repair work properly.

ALWAYS carefully follow Webasto installation and repair instructions and heed all WARNINGS.

Webasto rejects any liability for problems and damage caused by the system being installed by untrained personnel.



Air Top 2000 STC

Inhaltsverzeichnis

1	Gesetzliche Bestimmungen für den Einbau	1
2	Verwendung der Luftheizgeräte	5
3	Einbau	6
4	Typschild.	9
5	Einbaubeispiel.	10
6	Wärmeluftsystem	11
7	Brennstoffversorgung	13
8	Brennluftversorgung	18
9	Abgasleitung.	19
10	Brennluftansaug- und Abgasleitungen	20
11	Elektrische Anschlüsse	22
12	Anschlusschema / Schaltplan	25
13	Legende für Schaltpläne	30
14	Erstinbetriebnahme.	33
15	Störabschaltung	34
16	Technische Daten	36
17	Ausführung.	38
18	Bohrschablone	39

Table of Contents

1	Statutory regulations governing installation	41
2	Use of air heaters.	45
3	Installation	46
4	Type label.	49
5	Installation example.	50
6	Hot air system	51
7	Fuel supply.	53
8	Combustion air supply	58
9	Exhaust pipe	59
10	Combustion air intake and exhaust pipes.	60
11	Electrical Connections	62
12	Connection diagram/wiring diagram	65
13	Legend to wiring diagrams	70
14	Initial start-up	73
15	Fault switch-off	74
16	Technical data	76
17	Variants	78
18	Drilling template	79

Air Top 2000 STC

Statutory regulations governing installation

1 Statutory regulations governing installation

The Air Top 2000 STC heater has been type-tested and approved in accordance with ECE-R 10 (EMC) and ECE-R 122 (heater).

For approval number see Chapter 16, "Technical data".

Primarily, the stipulations of Part I and of Annex 7 to the Regulation ECE-R 122 must be observed for the installation.

NOTE:

The stipulations of this regulation are binding under the framework of the Directive 70/156/EEC and/or 2007/46/EC (for new vehicle models from 29/04/2009) and should also be observed in countries where there are no specific regulations.

See Chapter 1.2, "Excerpt from the directive ECE-R 122 Part I and Annex 7" and Chapter 1.3, "Excerpt from the directive ECE-R 122 Annex 9".

ATTENTION:

Failure to follow the installation instructions and the notes contained therein will lead to all liability being refused by Webasto. The same applies if repairs are carried out incorrectly or with the use of parts other than genuine spare parts. This will result in the invalidation of the type approval for the heater and therefore of its homologation / EC type licence.

1.1. Application of combustion heaters in vehicles for the transportation of dangerous goods.

Vehicles used for the purpose of transporting dangerous goods are type approval tested in accordance with ECE R 105. The following measures are derived for our combustion heaters.

- The electrical cable/wiring harness must be sufficiently dimensioned to prevent overheating. The electrical cable/wiring harness must be sufficiently insulated. All electrical circuits must be protected by fuses or automatic circuit breakers.
- The cables must be installed and firmly secured such that the wirings are adequately protected against mechanical and thermal stress.
- The combustion heaters must be type-tested in accordance with ECE R 122 (equivalent to EC/2001/56 in the version EC/2006/119) and comply with Annex 9 - Additional regulations for vehicles used for transporting dangerous goods.
- The combustion heaters and their exhaust gas piping system must be designed, arranged, protected or covered so as to prevent any unacceptable risk of heating or ignition of the load.
- In the event of a leak in the fuel line, the fuel must drain to the ground without coming into contact with hot parts of the vehicle or the load.
- The exhaust system as well as the exhaust pipes shall be so directed or protected to avoid any danger to the load through heating or ignition. Parts of the exhaust system situated directly below the fuel tank must have a minimum clearance of 100 mm or be protected by a heat shield.
- It must only be possible to switch the combustion heater on manually. Programming devices shall be prohibited.

Statutory regulations governing installation

Air Top 2000 STC

Requirements relating to the basic unit:

When switched off, it is permissible for combustion heaters to continue running for max. 40 seconds. Only combustion heaters are to be used with heat exchangers that are not damaged during their standard operating period by the reduced afterrunning time of 40 seconds.

1.2. Excerpt from the directive ECE-R 122 Part I and Annex 7

Start of excerpt.

Part I

5.3 Vehicle Installation Requirements for Combustion Heaters and for Electric Heaters

5.3.1 Scope

5.3.1.1 Subject to paragraph 5.3.1.2, heaters shall be installed according to the requirements of paragraph 5.3.

5.3.1.2 Vehicles of category O having liquid fuel heaters are deemed to comply with the requirements of paragraph 5.3.

5.3.2 Positioning of heater

5.3.2.1 Body sections and any other components in the vicinity of the heater must be protected from excessive heat and the possibility of fuel or oil contamination.

5.3.2.2 The heater shall not constitute a risk of fire, even in the case of overheating. This requirement shall be deemed to be met if the installation ensures an adequate distance to all parts and suitable ventilation, by the use of fire resistant materials or by the use of heat shields.

5.3.2.3 In the case of M2 and M3 vehicles, the combustion heater must not be positioned in the passenger compartment. However, an installation in an effectively sealed envelope which also complies with the conditions in paragraph 5.3.2.2 may be used.

5.3.2.4 The label referred to in Annex 7, paragraph 4, or a duplicate, must be positioned so that it can be easily read when the combustion heater is installed in the vehicle.

5.3.2.5 Every reasonable precaution should be taken in positioning the heater to minimize the risk of injury and damage to personal property.

5.3.3 Fuel supply

5.3.3.1 The fuel filler must not be situated in the passenger compartment and must be provided with an effective cap to prevent fuel spillage.

5.3.3.2 In the case of liquid fuel heaters, where a supply separate from that of the vehicle is provided, the type of fuel and its filler point must be clearly labelled.

5.3.3.3 A notice, indicating that the heater must be shut down before refuelling, must be affixed to the fuelling point. In addition a suitable instruction must be included in the manufacturer's operating manual.

5.3.4 Exhaust system

5.3.4.1 The exhaust outlet must be located so as to prevent emissions from entering the vehicle through ventilators, heated air inlets or opening windows.

5.3.5 Combustion air inlet

5.3.5.1 The air for the combustion chamber of the heater must not be drawn from the passenger compartment of the vehicle.

5.3.5.2 The air inlet must be so positioned or guarded that blocking by rubbish or luggage is unlikely.

5.3.6 Heating air inlet

5.3.6.1 The heating air supply may be fresh or re-circulated air and must be drawn from a clean area not likely to be contaminated by exhaust fumes emitted either by the propulsion engine, the combustion heater or any other vehicle source.

Air Top 2000 STC

Statutory regulations governing installation

5.3.6.2 *The inlet duct must be protected by mesh or other suitable means.*

5.3.7 Heating air outlet

5.3.7.1 *Any ducting used to route the hot air through the vehicle must be so positioned or protected that no injury or damage could be caused if it were to be touched.*

5.3.7.2 *The air outlet must be so positioned or guarded that blocking by rubbish or luggage is unlikely.*

5.3.8 Automatic control of the heating system

5.3.8.1 *The heating system must be switched off automatically and the supply of fuel must be stopped within five seconds when the vehicle's engine stops running. If a manual device is already activated, the heating system can stay in operation.*

ANNEX 7

ADDITIONAL REQUIREMENTS FOR COMBUSTION HEATERS

7 Warning light

7.1 *A clearly visible tell-tale in the operator's field of view shall inform when the combustion heater is switched on or off.*

End of excerpt.

NOTE:

If the installation location of the heater is not located behind the driver's seat and can be reached by the driver under normal operating conditions, supplementary to Point 5.3.2.3, the heater must only be installed in an effectively sealed housing (that also conforms to the regulations of Paragraph 5.3.2.2) in vehicles of Class M1 (passenger vehicles and motor homes), M2 and M3 (coaches) as well as N (transporters and commercial vehicles).

The installation of the heater in a place that is inaccessible while driving or in a suitable enclosure conforming to Paragraphs 5.3.2.2 and 5.3.2.5 is recommended in order to avoid unintentional contact with the heater surface and possible injuries.

1.3. Excerpt from the directive ECE-R 122 Annex 9

Start of excerpt.

Additional provisions applicable to certain vehicles as specified in the ADR

3. Technical Provisions

3.1 General (EX/II, EX/III, AT, FL, OX and MEMU vehicles)

3.1.1 [1] *The combustion heaters and their exhaust gas routing shall be designed, located, protected or covered so as to prevent any unacceptable risk of heating or ignition of the load. This requirement shall be considered as fulfilled if the fuel tank and the exhaust system of the appliance conform to the following provisions:*

- *Any fuel tanks for supplying the appliance shall meet the following requirements:*
 - a) *In the event of any leakage, the fuel shall drain to the ground without coming into contact with hot parts of the vehicle or the load;*
 - b) *Fuel tanks containing petrol shall be equipped with an effective flame trap at the filler opening or with a closure enabling the opening to be kept hermetically sealed.*
- *The exhaust system as well as the exhaust pipes shall be so directed or protected to avoid any danger to the load through heating or ignition. Parts of the exhaust system situated directly below the fuel tank (diesel) shall have a clearance of at least 100 mm or be protected by a thermal shield.*

Statutory regulations governing installation

Air Top 2000 STC

3.1.2 The combustion heater shall be switched on manually. Programming devices shall be prohibited.

3.2 EX/II, EX/III and MEMU vehicles

Combustion heaters using gaseous fuels are not permitted.

3.3 FL vehicles

3.3.1 The combustion heaters shall be put out of operation by at least the following methods:

- a) Intentional manual switching off from the driver's cab;
- b) Stopping of the vehicle engine; in this case the heating device may be restarted manually by the driver;
- c) Start up of a feed pump on the motor vehicle for the dangerous goods carried.

[1] Compliance with this paragraph shall be verified on the completed vehicle.

End of excerpt.

Air Top 2000 STC

Use of air heaters

2 Use of air heaters

The Webasto Air Top 2000 STC air heaters are designed

- to heat cabins, boats, commercial vehicles, minibusses, vans/transporters and motor homes
- to defrost vehicle windows.

The heaters operate independently of the engine and are connected directly to the fuel tank and the electrical system of the vehicle.

They are not approved for heating dangerous goods/hazardous substances.

3 Installation

ATTENTION:

Comply with the legal requirements for installation on Page 41 and 42. The requirements stipulated in the latest version of the ADR must be additionally observed for the installation of the heater in vehicles used to transport dangerous goods/hazardous substances.
The heater must not be operated without the control unit cover (this will cause the heater to overheat).

3.1. Air Top 2000 STC installation situation

NOTE:

Check the given conditions for installation in the respective type of vehicle.

3.2. Installation location

The heater may be installed both in the interior or on the exterior of the vehicle.

When using the vehicle in normal road traffic, the heater may only be installed with a contact guard to prevent contact if it is located within the reach of the driver.

If installed on the exterior, ensure that the heater is fitted in a position where it is protected from splash water and spray.

The heater must be installed in such a way that no water can enter the heater when the vehicle is driven through water conforming to the permissible fording level.

The openings for the combustion air inlet, the exhaust gas outlet and the fuel pipe must be sealed. The seal designed and supplied for this purpose must be used.

(See Fig. 3).

3.3. Heater installation

When installing the Air Top 2000 STC heater, tighten the M6 nuts to a torque of 6 Nm +1.

The installation dimensions and space requirements for service access are shown in the installation drawing (Fig. 1). The specified horizontal and axial angles of inclination must not be exceeded (Fig. 2).

A seal (Fig. 3) must be fitted between the heater and the vehicle body. **The seal must be replaced each time the heater is reinstalled.** The support surface for the heater base **must be flat.** The seal can compensate for unevenness of max. 1 mm.

ATTENTION:

After installation check that the casing is not in contact with any part of the boat's body. Failure to do this may result in the heating air fan blocking.

Installation

Air Top 2000 STC

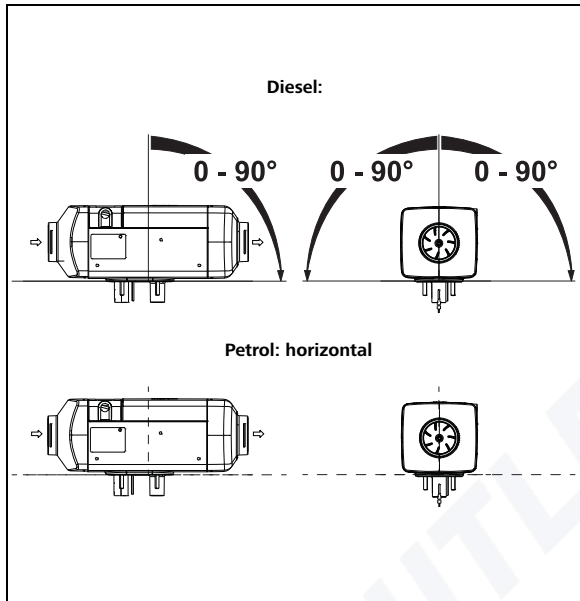

Fig. 2: Permissible heater installation positions

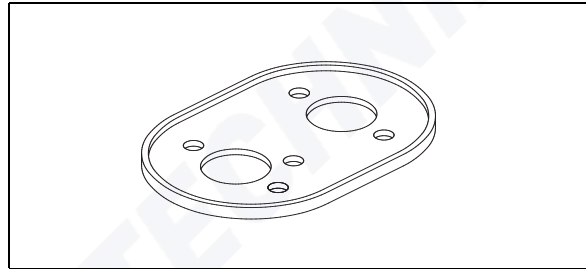

Fig. 3: Seal

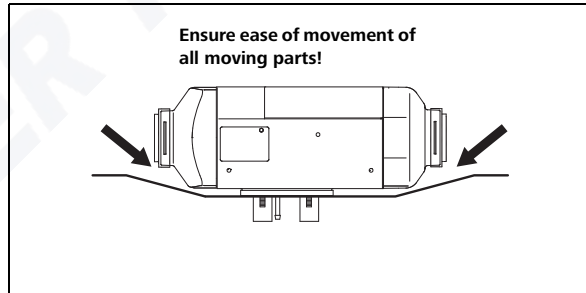

Fig. 4: Installation

Air Top 2000 STC

Type label

4 Type label

If the type label is not visible with the heater in installed position, a duplicate of the type plate must be displayed in a position where it is clearly visible and protected from damage.

Year figures that do not apply must be removed from the type label.

Installation example

Air Top 2000 STC

5 Installation example

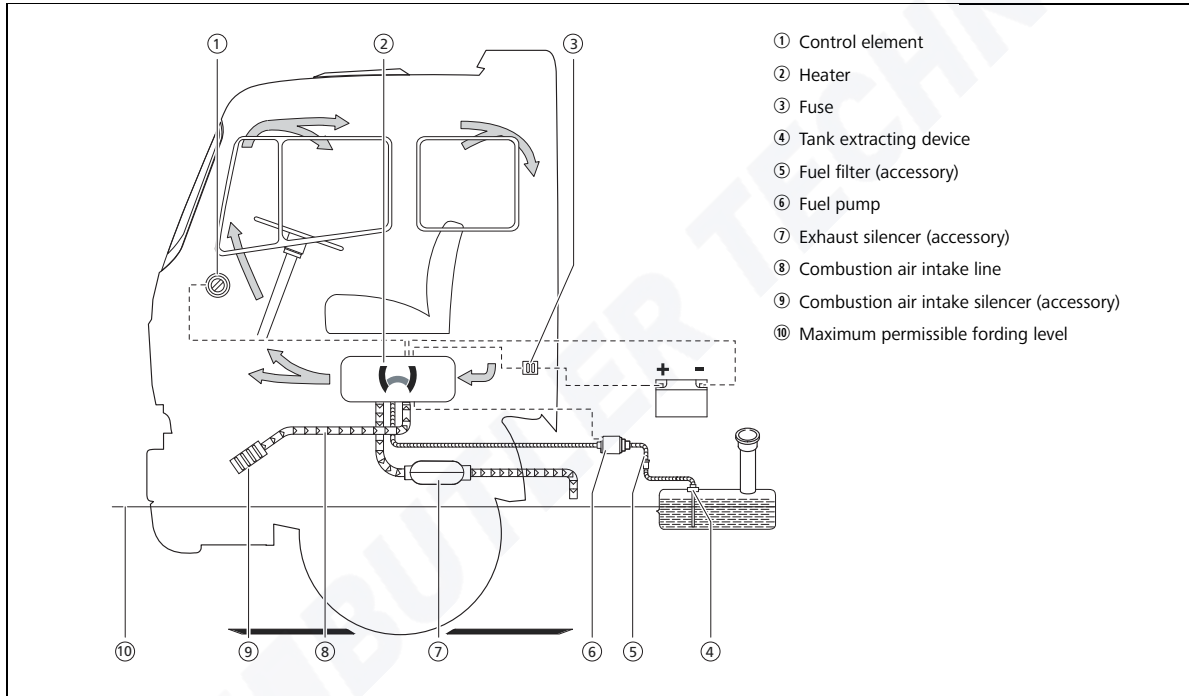

Fig. 5: Installation example of air heater in recirculated air mode

Air Top 2000 STC

Hot air system

6 Hot air system

NOTE:

it is not permitted to integrate the heater into the vehicle's air circulation system.

A temperature sensor, which measures the room temperature, is mounted on the inside of the control unit. The required interior temperature is selected at the control element. The heating capacity is adapted automatically to the heating requirements of the room.

Both recirculation and fresh air modes are permitted.

Care must be taken for fresh air mode to ensure that the cold air is taken from an area protected from splash water and spray and in such a way that no water can enter the heater when the vehicle is driven through water conforming to the permissible fording level.

NOTE:

For fresh air mode, a room temperature sensor must be installed in the area to be heated.

The inside diameter of the main section of the hot air duct should be 60 mm.

NOTE:

Only materials that can permanently withstand temperatures of at least 130 °C are to be used for the hot air duct. The hot air opening is to be positioned such that heat-sensitive parts are not damaged.

ATTENTION:

Every reasonable precaution should be taken in positioning the heater to minimize the risk of injury and damage to personal property.

Maximum pressure drop between the intake and pressure side of the hot air duct: 1.5 hPa

If this pressure drop is exceeded, the heater will reduce the heating capacity or shut down.

The hot air hose is to be secured at the connection points.

Avoid a short-circuit in the hot air flow when the heater is used in recirculated air mode.

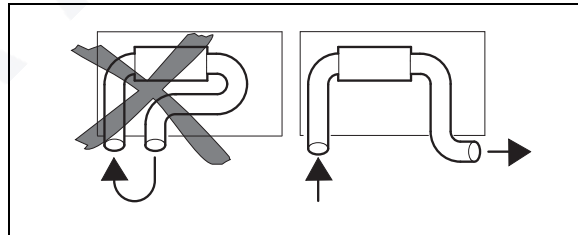

Fig. 6: Cold air inlet and hot air outlet

Hot air system

Air Top 2000 STC

ATTENTION:

Suitable grilles must be fitted on the cold air inlet and hot air outlet if the heater is used without air guides.

NOTE:

The installation must be checked for:

- excessively high cold air intake temperature due to the vehicle heating system
- for air short-circuit between the cold air inlet and hot air outlet of the heater (Fig. 6).

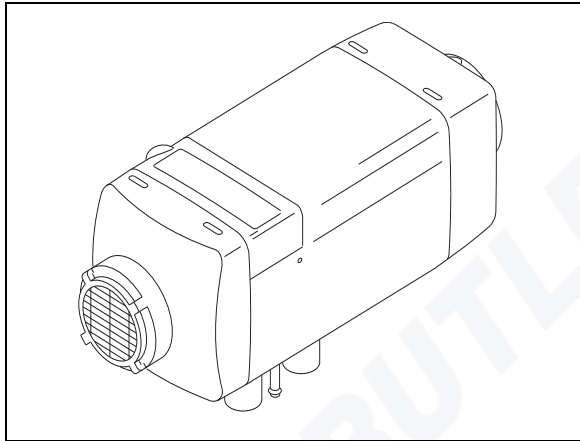

Fig. 7: Cold air inlet with mesh guard

If a casing is used, the hot air duct leading out of the box must be sealed.

6.1. Room temperature sensor

For fresh air mode, a room temperature sensor must be installed in the area to be heated.

6.1.1. Room temperature sensor installation

The room temperature sensor must be installed at medium height in the vehicle cabin on vertical surfaces in the area to be heated.

The room temperature sensor must **not**

- be in the direct flow of hot air (from vehicle heating system or hot air heater).
- be installed in the vicinity of heat sources (e.g. vehicle heating system).
- be placed in direct sunlight (e.g. dashboard).
- be installed behind curtains or similar.

Air Top 2000 STC

Fuel supply

7 Fuel supply

The fuel is taken from the vehicle's fuel tank or from a separate fuel tank. Refer to Chapter 7.1.4, "Pipe lengths and delivery head" for the permissible pressure at the fuel take-off point.

A notice, indicating that the heater must be shut down before refuelling, must be affixed to the filler neck.

7.1. Fuel lines

7.1.1. Vehicles with carburetor engine

The fuel may only be extracted with the special Webasto fuel extractor (Fig. 8) as close to the fuel tank as possible. The connection can be made either in the supply or return line, where the return line must extend almost to the bottom of the fuel tank.

The fuel extractor must be installed in such a way that any air or gas bubbles are automatically expelled towards the fuel tank (Fig. 8).

Fuel should be extracted in the vicinity of the engine as gas bubbles can form in the lines in this area due to the heat radiated from the engine. This can cause combustion problems.

7.1.2. Vehicles with fuel injection engine

When installing the heater in a vehicle with a fuel injection system, it is important to establish whether the fuel pump is located inside or outside the fuel tank.

If the fuel pump is located inside the fuel tank, fuel can only be extracted from the return line using the Webasto fuel extractor (Fig. 8). In this case it is necessary to ensure that the return line extends almost to the bottom of the fuel tank (otherwise the Webasto tank extracting device (Fig. 9, Fig. 10 and Fig. 11) can be used.

If the fuel pump is installed outside the fuel tank, the fuel connection can be

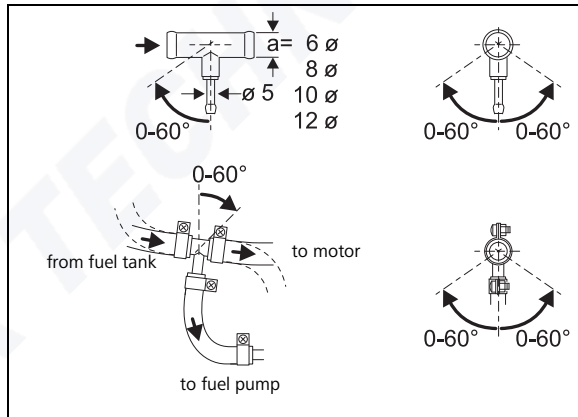

Fig. 8: Webasto fuel extractor

made between the fuel tank and the fuel pump, again using only the Webasto fuel extractor (Fig. 8).

7.1.3. Extracting fuel with tank extracting device

Fuel must be extracted from the fuel tank or a separate tank (Fig. 8, Fig. 9 and Fig. 10). Separate fuel extraction has no influence on the pressure.

Fuel supply

Air Top 2000 STC

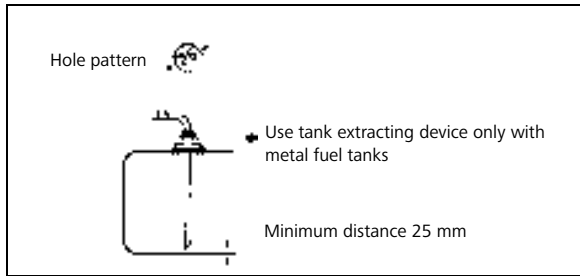

Fig. 9: Webasto tank extracting device

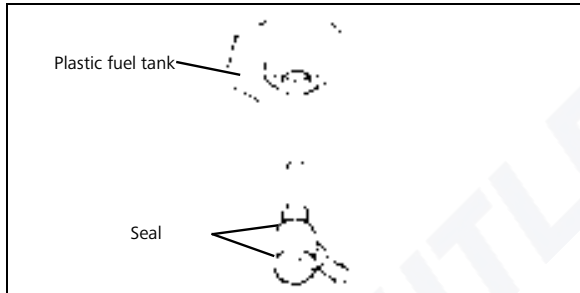

Fig. 10: Extracting fuel from plastic fuel tank
(fuel take-off via tank drain plug)

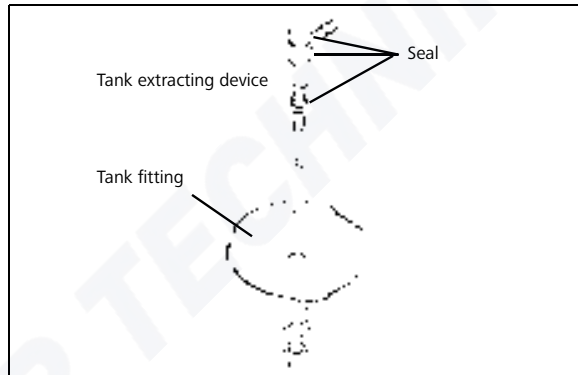

Fig. 11: Extracting fuel from plastic fuel tank
(fuel take-off via tank fitting)

Air Top 2000 STC

Fuel supply

7.1.4. Pipe lengths and delivery head

When installing the fuel line make sure that it is kept as short as possible.

See Fig. 12.

The pipe must be installed such as to protect it from being damaged.

The fuel line must be installed in cool areas to avoid bubbles being formed by the effect of heat. High fuel temperatures can cause the heater to malfunction.

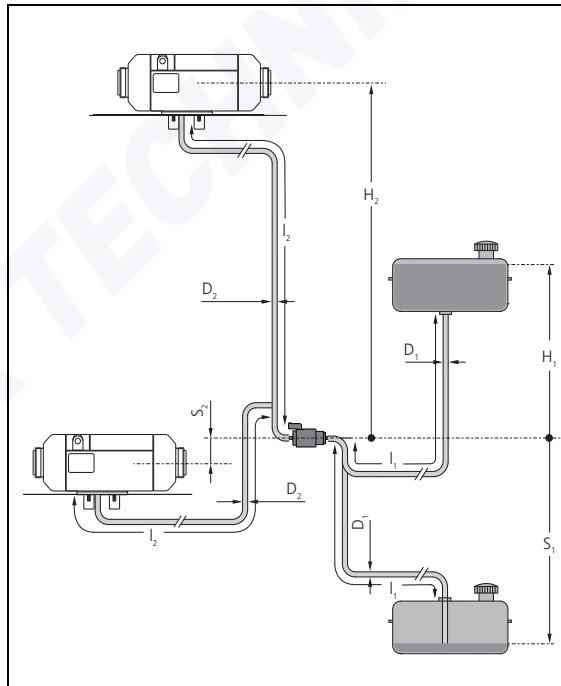

Fig. 12: Fuel supply

Fuel supply

Air Top 2000 STC

The fuel lines must be secured using state-of-the-art fastening elements. Do not damage the fuel line.

Intake side:

D_1 : Inside diameter of fuel line = 2 mm.

H_1 : Fuel level (tank above fuel pump) [m]

S_1 : Fuel level (tank below fuel pump) [m]

l_1 : Length of fuel line [m]

Pressure side:

D_2 : Inside diameter of fuel line = 2 mm.

H_2 : Height difference between heater and fuel pump (heater above fuel pump) [m]

S_2 : Height difference between heater and fuel pump (heater below fuel pump) [m]

l_2 : Length of fuel line [m]

Fuel level (tank above fuel pump), H_1 [m]	Maximum permissible fuel pressure at take-off point, p_1 [bar]
$H_1 = 0$	$-0.1 < p_1 \leq +0.5$
$0 < H_1 < 1$	$-0.1 < p_1 \leq +0.4$
$1 < H_1 < 2$	$-0.1 < p_1 \leq +0.3$

Fuel level (tank below fuel pump), H_2 [m]	Maximum permissible fuel pressure at take-off point, p_1 [bar]
$0 < H_2 < 1.3$	$-0.1 < p_1 \leq +0.5$

Parameter	Value
Length of intake pipe l_1 [m]	max. 5
Length of pressure pipe l_2 [m]	max. 10
Length of intake pipe l_1 + length of pressure pipe l_2 [m]	max. 12
Height difference between heater and fuel pump (heater above fuel pump) H_2 [m]	max. 3
Height difference between heater and fuel pump (heater below fuel pump) S_2 [m]	max. 1

7.1.5. Pipe material

Only use steel or plastic fuel lines made from light and temperature-resistant material in accordance with DIN 73379 as the fuel pipes.

7.1.6. Connecting 2 fuel lines with a hose

Fig. 13 shows the correct connection of fuel lines with a hose. Make sure there are no leaks!

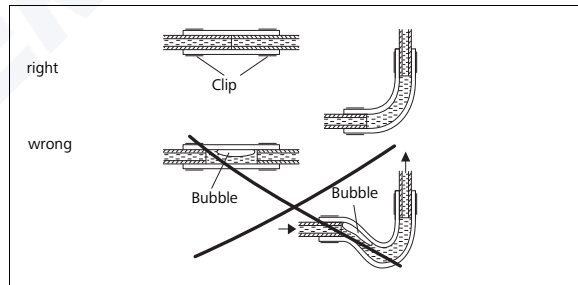

Fig. 13: Pipe/hose connection

Air Top 2000 STC

Fuel supply

- Secure the line at regular intervals to prevent sagging. Avoid kinks.
- Keep away from heat sources. Use heat shield if necessary!

7.2. Fuel pump

The fuel pump is a combined delivery, metering and a shut-off system and is subject to certain installation criteria (see Fig. 14).

7.2.1. Installation location

The fuel pump must be installed in a cool place as close as possible to the fuel tank (see Chapter 7.1.4, "Pipe lengths and delivery head"). For petrol heaters, the ambient temperature must not exceed +20 °C at any time during operation.

The fuel pump and fuel lines must not be installed within the range of radiated heat from hot vehicle parts. A heat shield should be fitted if necessary.

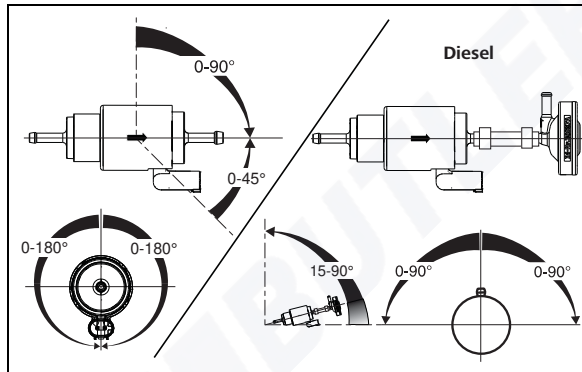

Fig. 14: DP42 fuel pump installation position

7.2.2. Installation and attachment

The fuel pump must be secured with a vibration-damping mounting (e.g. rubberised clip). The installation position is limited as shown in Fig. 14 to ensure effective automatic bleeding.

Due to the risk of corrosion only genuine Webasto parts must be used for the plug connection between the fuel pump and fuel pump wiring harness. Use the flexible mount to install the fuel pump (reduces the transmission of structure-borne noise/ticking)! (see Fig. 15).

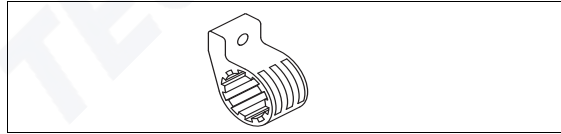

Fig. 15: Flexible mount of fuel pump

7.3. Fuel filter

Only a Webasto strainer is to be fitted if poor-quality fuel is used. Install vertically if possible, maximum deviation not exceeding 90° (ensure correct direction of flow).

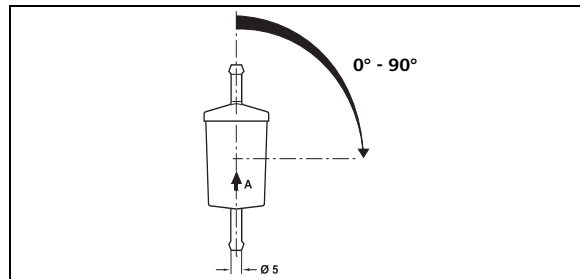

Fig. 16: Fuel filter

8 Combustion air supply

Under no circumstances may the combustion air be taken from areas occupied by persons. The combustion air intake opening must not face in the direction of travel. It must be arranged in such a way that it cannot become clogged with dirt.

NOTE:

It is recommended to install an intake silencer if the length of the intake hose is less than 0.6 m.

NOTE:

Using a combustion air line, the combustion air must be taken from a position that is as cool as possible and protected from splash water. Only use the supplied and Webasto-approved combustion air lines for this purpose.

The combustion air opening must not be below the fording height permitted for the respective vehicle.

See statutory installation requirements for further regulations.

9 Exhaust pipe

Rigid pipes made from unalloyed or alloyed steel with a minimum wall thickness of 1.0 mm or flexible piping made of alloyed steel must be used for the exhaust pipe.

The exhaust pipe is secured to the heater with the supplied exhaust pipe clamp. See statutory requirements for further regulations.

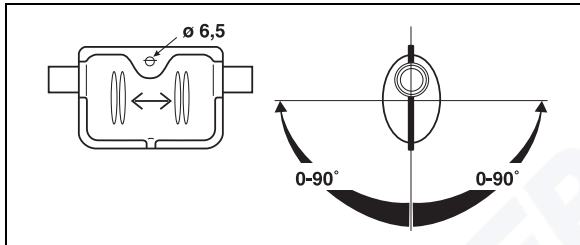

Fig. 17: Exhaust silencer

Direction of flow arbitrary

The exhaust silencer should preferably be installed close to the heater.
The heater can also be operated without a silencer.

Combustion air intake and exhaust pipes

Air Top 2000 STC

10 Combustion air intake and exhaust pipes

Both pipes must be installed falling away from the heater. If this is not possible, make a \varnothing 4 mm condensation drain hole at the lowest point.

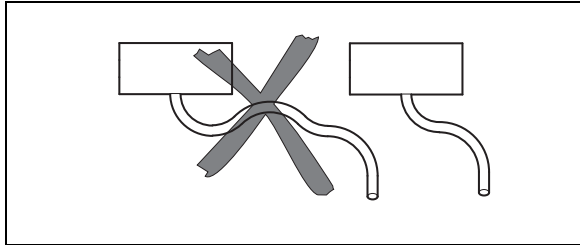

Fig. 18: Prevent condensation forming

The pipes must not face in the direction of travel.

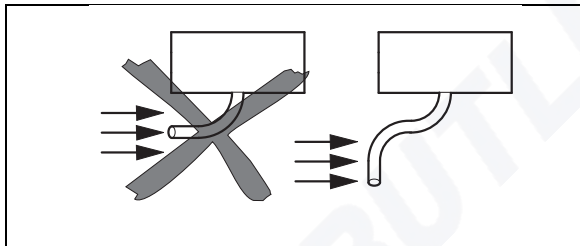

Fig. 19: Pipe ends not facing in direction of travel

The pipes must be arranged in such a way that it cannot become clogged with dirt.

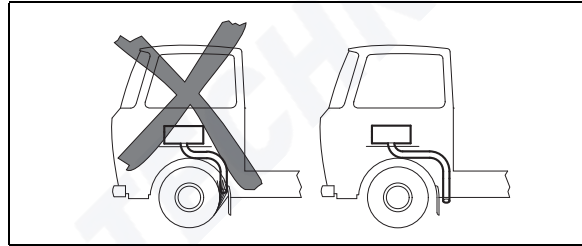

Fig. 20: Prevent pipes becoming clogged with dirt

ATTENTION:

Risk of fire if the exhaust pipe ends other than shown in Fig. 21!

Length of combustion air intake and exhaust pipe in total:

with silencer:	max. 2.0 m
without silencer:	max. 5.0 m

NOTE:

Exhaust pipes longer than 2 m must be insulated (to prevent dropping below dew point)

Inside diameter of pipes:

Combustion air line:	22 mm
Exhaust pipe (metal):	22 mm

Smallest bending radius: 50 mm

Total bends:

combustion air line:	max. 270°
Exhaust pipe:	max. 270°

Air Top 2000 STC

Combustion air intake and exhaust pipes

Attachment no further than 150 mm from the end of the exhaust pipe is required to achieve the required angle of $90^\circ \pm 10^\circ$.

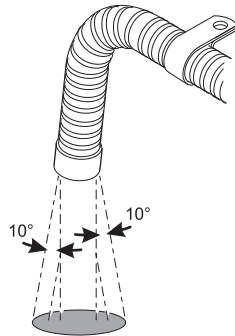

Outflow direction almost vertical $90^\circ \pm 10^\circ$

Fig. 21: End of exhaust pipe
Installation position

Electrical Connections

Air Top 2000 STC

11 Electrical Connections

All lines that are not required must be insulated!

11.1. Connection for installation in a vehicle for transporting dangerous goods (ADR)

The requirements stipulated in the ADR/RID Part 9, 9.2.4.7 Combustion Heaters must be additionally observed for the installation of the Air Top 2000 STC D heaters in vehicles used to transport dangerous goods. The electrical connection is made as shown in the wiring diagram Fig. 31 or Fig. 32. On vehicles without power take-off, the electrical connection must be made as shown in the system wiring diagram Fig. 32.

NOTE:

The switch S3 must be installed in such a way that a positive voltage is connected to the corresponding input of the control unit when a pumping device is started up.

ATTENTION:

In accordance with the stipulations of the ordinance governing the road/rail haulage of hazardous substances, heaters are to be placed into service only with a manually operated switch installed in the driver's cab.

Operation of the heater in ADR vehicles is only permitted with a manual switch.

11.2. Connecting heater

To connect the heater, remove the control unit cover on the heater and plug in the wiring harness connector at the control unit.

NOTE:

Use a blunt blade on both sides to remove the control unit cover (Fig. 22, arrows).

To prevent the hot air escaping (heater overheating), reattach the control unit cover prior to initial start-up.

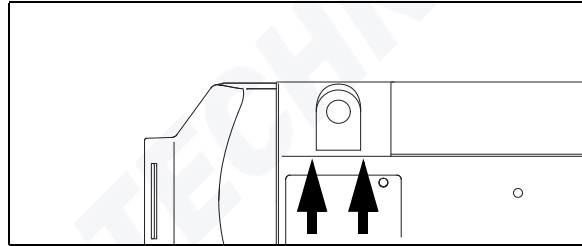

Fig. 22: Removing control unit cover

The cable lead-through can be either on the left or right. Correspondingly position the cable grommet on the wiring harness to ensure that the cable lead-through is sealed off in the control unit cover.

11.3. Supply voltage connection

Preferably from the vehicle's central electrical system.

Air Top 2000 STC

Electrical Connections

An additional blade terminal fuse holder is to be installed to protect the heater (supplied with the heater). The fuse holder must only be installed in the vehicle interior.

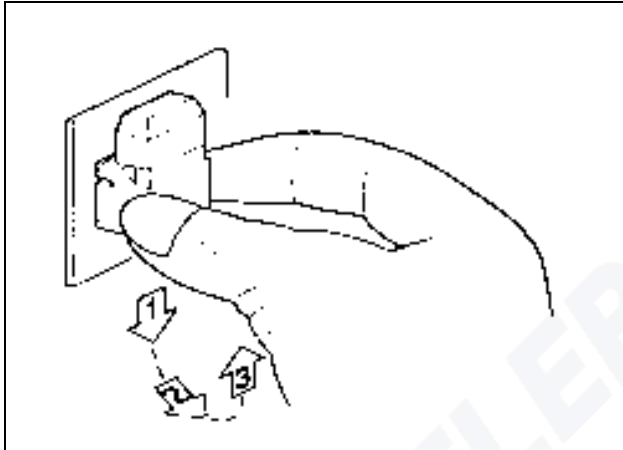

Fig. 23: Removing mounting plate on fuse holder

F = 15A
(12 and 24V)

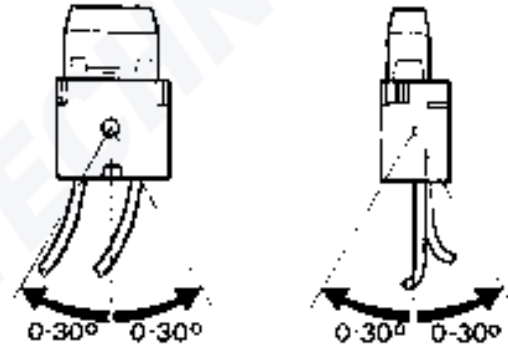

Fig. 24: Fuse holder, installation position

Electrical Connections

Air Top 2000 STC

11.4. Control element connection

The wiring harness is prepared for connection to the control element.
Only pull on the connector housing to unplug the connector.
The connector housing will lock (self-locking action) by pulling on the wiring harness.

NOTE:

The fibre optic cable must make contact with the rotary knob .

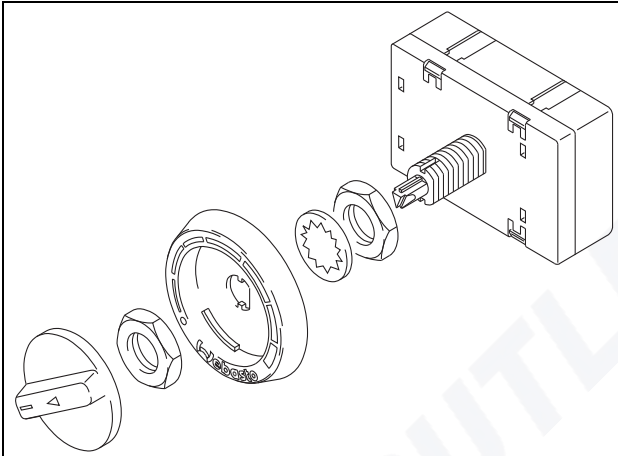

Fig. 25: Control element

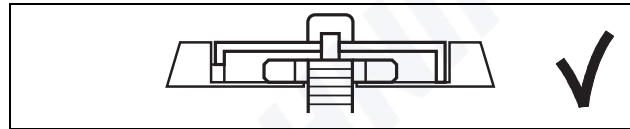

Fig. 26: Installation of control element

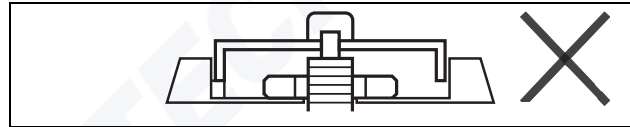

Fig. 27: Installation of control element (wrong)

Air Top 2000 STC

Connection diagram/wiring diagram

12 Connection diagram/wiring diagram

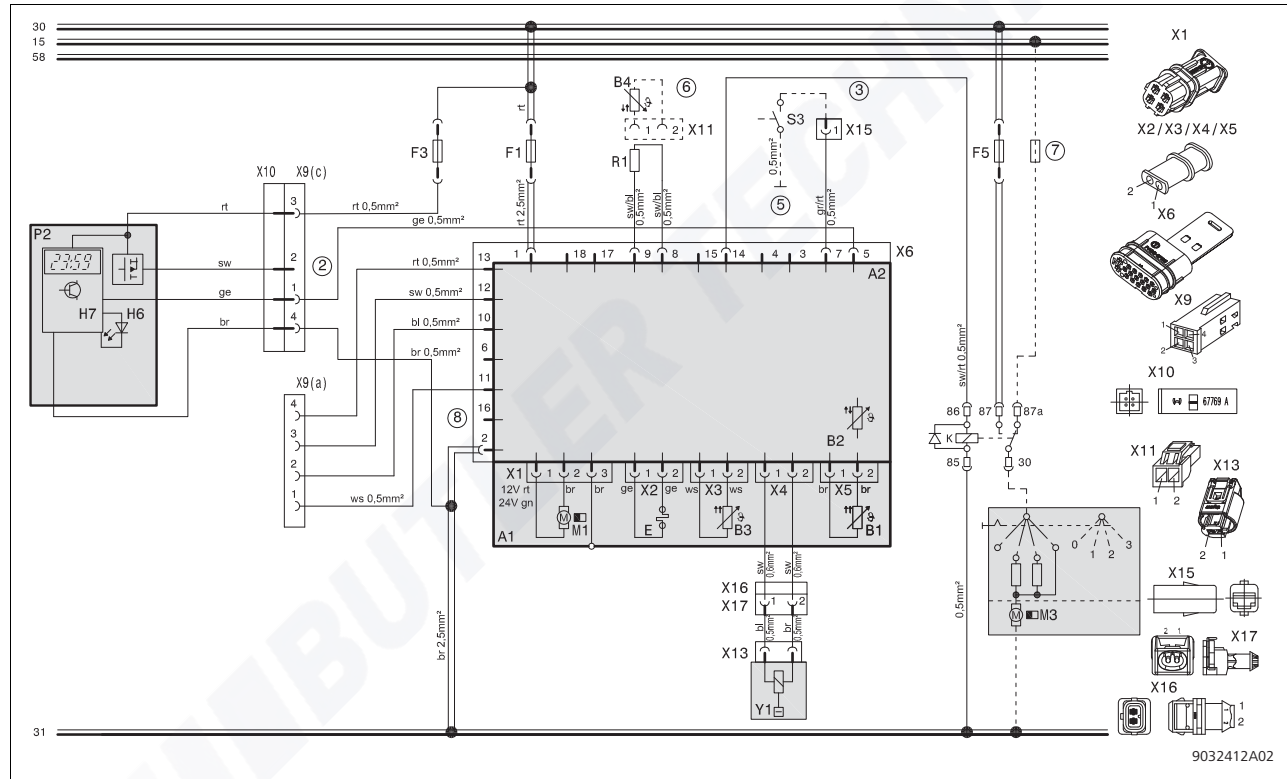

Fig. 28: System wiring diagram Air Top 2000 STC, 12 V/24 V with MultiControl, see Page 70 for legend

Connection diagram/wiring diagram

Air Top 2000 STC

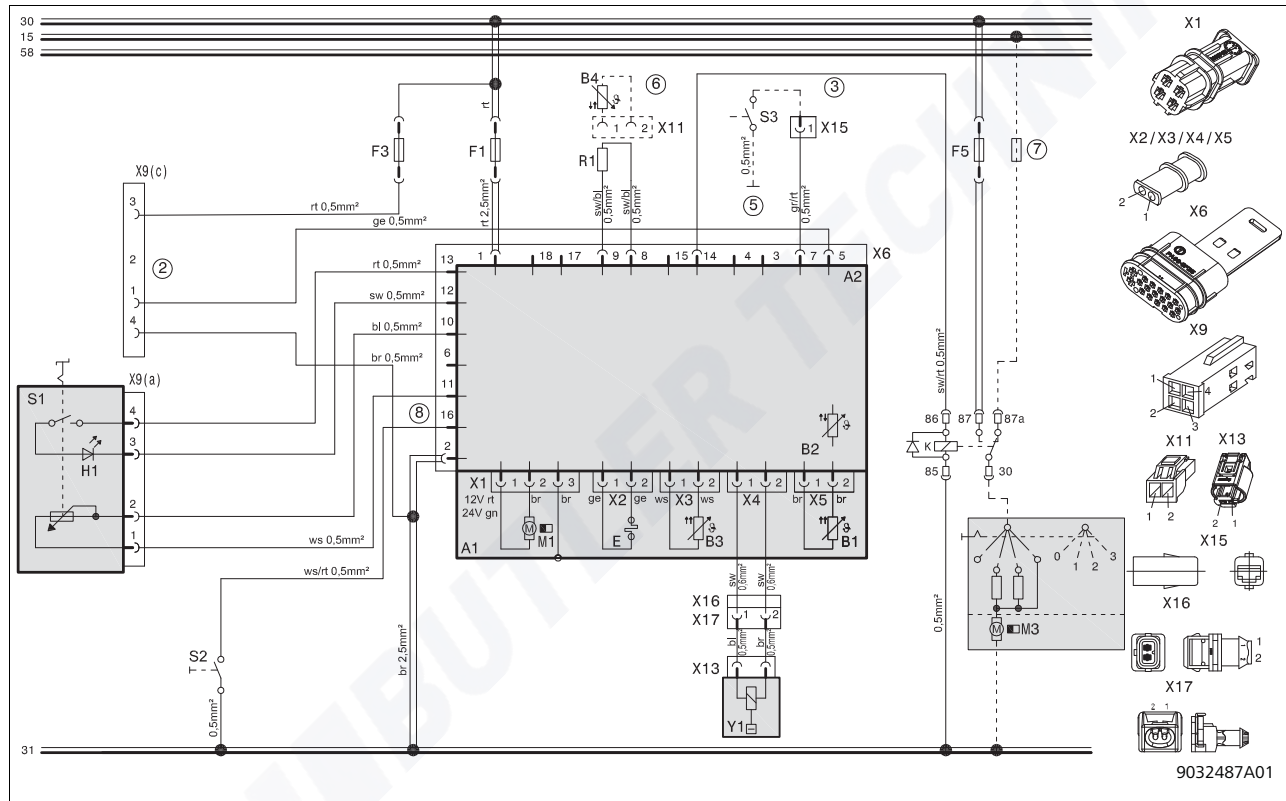

Fig. 29: System wiring diagram Air Top 2000 STC, 12 V/24 V with control element and vehicle fan, see Page 70 for legend

Air Top 2000 STC

Connection diagram/wiring diagram

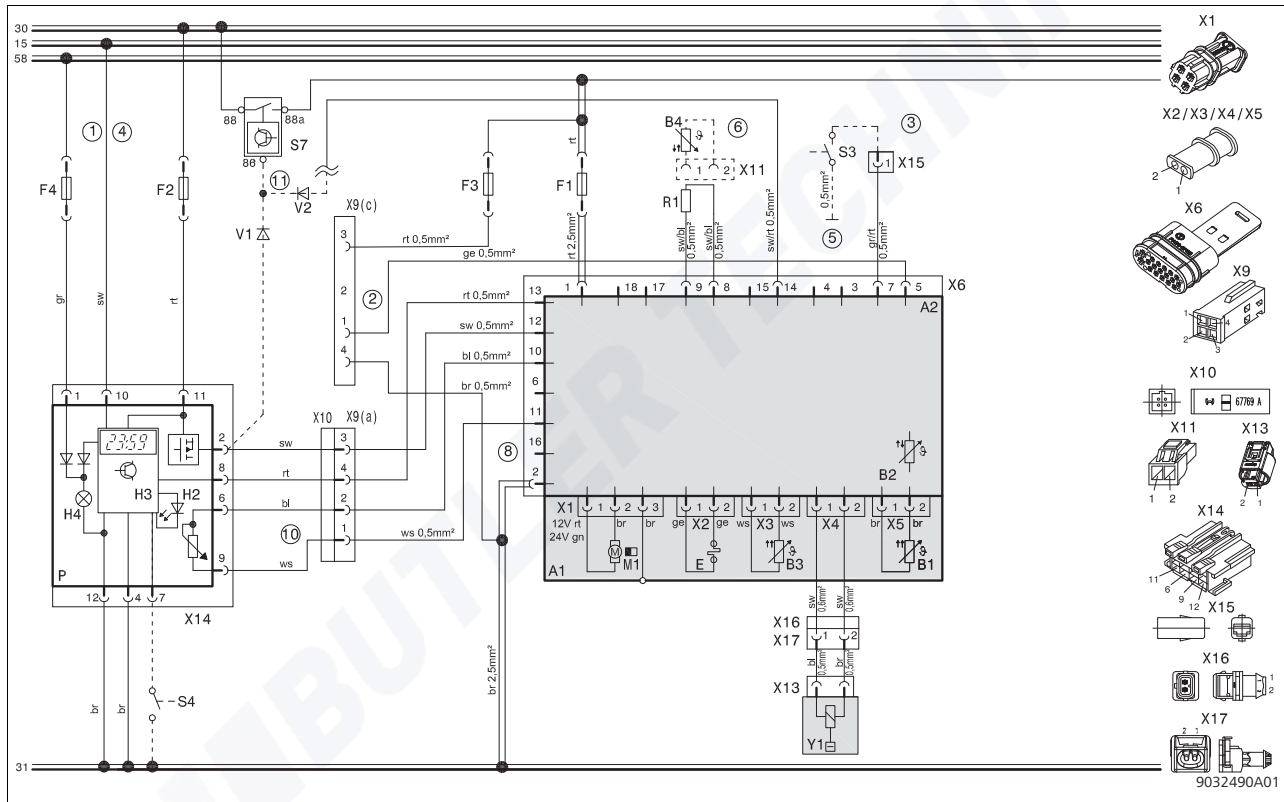
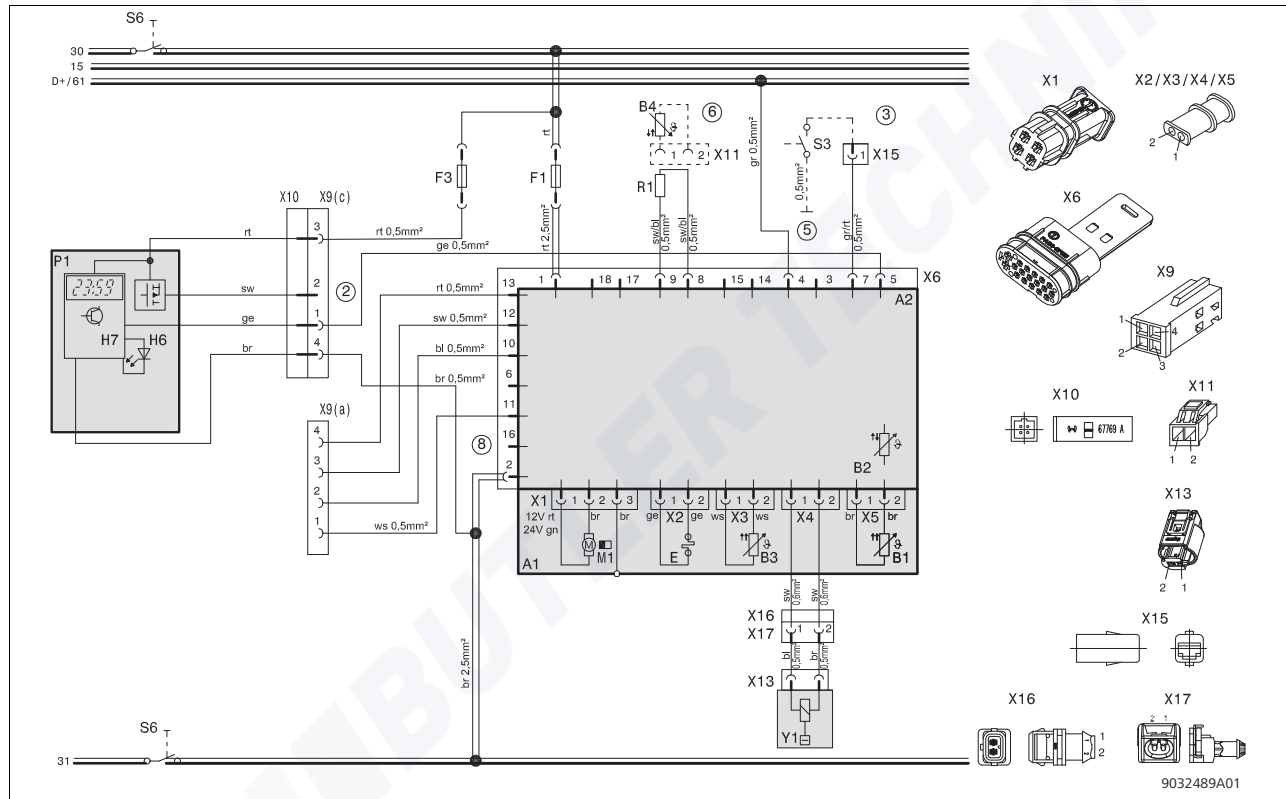

Fig. 30: System wiring diagram Air Top 2000 STC, 12 V/24 V with standard timer/combination timer, see Page 70 for legend

Connection diagram/wiring diagram

Air Top 2000 STC



9032489A01

Fig. 31: System wiring diagram Air Top 2000 STC D, 12 V/24 V ADR-operation with SmartControl, see Page 70 for legend

Air Top 2000 STC

Connection diagram/wiring diagram

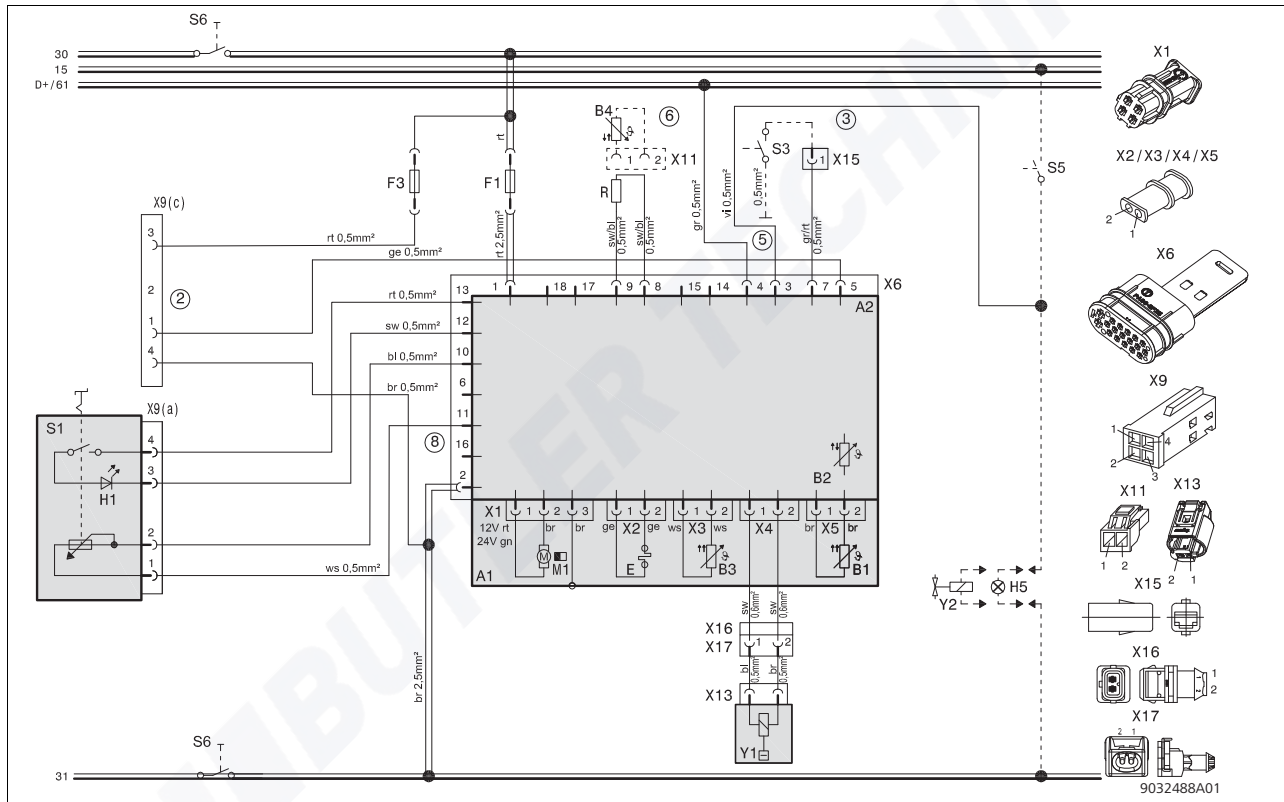



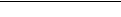
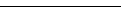

Fig. 32: System wiring diagram Air Top 2000 STC, 12 V/24 V ADR-operation with control element, see Page 70 for legend

Legend to wiring diagrams

Air Top 2000 STC

13 Legend to wiring diagrams

Cable cross-sections		
	< 7.5 m	7.5 - 15 m
	0.75 mm ²	1.0 mm ²
	1.0 mm ²	1.5 mm ²
	1.5 mm ²	2.5 mm ²
	2.5 mm ²	4.0 mm ²
	4.0 mm ²	6.0 mm ²

Cable colours	
bl	blue
br	brown
ge	yellow
gn	green
gr	grey
or	orange
rt	red
sw	black
vi	violet
ws	white

Item	Description	Remarks
A1	Heater	Air Top 2000 STC
A2	Control unit	Control unit
A3	UniBox	-
B1	Flame monitor	Only for petrol heaters
B2	Temperature sensor	Inside
B3	Overheat sensor	Overheating protection
B4	Room temperature sensor	Outside
E	Glow plug	-
F1	Fuse 24 V, 15 A 12 V, 15A (max. 20 A)	Blade fuse DIN 72581-3
F2	Fuse 1A	Not included in wiring harness
F3	Fuse 1A	Blade fuse DIN 72581-3
F4	Fuse 1A	Not included in wiring harness
F5	Fuse	Value [in A] to be selected corresponding to wire cross section; not included in wiring harness
H1	LED green (in Item S1)	ON indicator, fault code indicator
H2	LED red (in Item P)	Lighting: Quick Heating button, Ready indicator, ON indicator
H3	Heating symbol on display (in Item P)	ON indicator, ready indicator

Air Top 2000 STC

Legend to wiring diagrams

Item	Description	Remarks
H4	Bulb/LED (in Item P)	Display and button lighting
H5	Bulb/LED	ON indicator, pumping device (max. 500 mA)
H6	LED (green, blue, white, red)	Operation indicator, Ready indicator, ON indicator, fault list
H7	Symbol on display	-
K	Relay with free-wheeling diode	Vehicle blower (max. 500 mA)
M1	Drive motor	Heating and combustion air fan
M3	Motor	Vehicle blower
P	Combi timer 1531	Combination digital timer and setpoint sensor
P1	SmartControl	(W-bus)
P2	MultiControl or SmartControl	(W-bus)
R1	Resistor	Only for internal temperature sensor
S1	Control element (rotary switch)	ON/OFF switch and temperature setpoint sensor
S2	Switch	Ventilation
S3	Switch	CO ₂ setting
S4	Pushbutton	External Quick Heating button
S5	Switch	auxiliary drive / pumping device
S6	Switch, 1 or 2-pin	Disconnecter
S7	Battery disconnecter	Electronically controlled disconnecter (max. 500 mA)

Item	Description	Remarks
V1-V2	Blocking diode	Min. 500 mA
X1-X6	Plug connection	To Item A2
X9	Plug connection	-
X9 (a)	Plug connection	To Item S1
X9 (c)	Plug connection	W-bus, connection SmartControl/ MultiControl, Telestart (12 V only), ThermoCall or diagnosis
X10	Plug connection	To Item P1 or P2
X11	Plug connection (optional)	To Item B4
X13	Plug connection	To Item Y1
X14	Plug connection	To Item P
X15	Plug connection (optional)	To Item S3
X16	Plug connection	Wiring harness connection DP42
X17	Plug connection	Wiring harness connection DP42
Y1	Fuel pump	DP42
Y2	Solenoid valve / pump	Auxiliary drive / pumping device

Legend to wiring diagrams

Air Top 2000 STC

Item	Remarks
①	Positive from terminal 15/75 to connection 10: Continuous heating mode is possible in connection with quick heating function provided the ignition is switched on.
②	All heater versions: connection W-bus diagnosis, SmartControl/ MultiControl, ThermoCall or Telearstart (12V only).
③	CO2 setting (see workshop manual)
④	Connection to terminal 30: Continuous heating mode is possible with ignition switched off.
⑤	Grey and violet wires required for ADR function. Non-ADR vehicles: Insulate and tie back ends of wires.
⑥	External room temperature sensor (optional)
⑦	Fuse in vehicle.
⑧	Pin 16 "Ventilate" (only for operation with control elements without W-bus)
⑨	The connection is not permitted for use of the combination timer 1531 in ADR vehicles.
⑩	Wiring harness adapter (optional)
⑪	Switching capacity 250 mA

13.1. Pin assignments plug connection X6, 18-pin

Pin No.	Remarks
1	Power supply + (terminal 30)
2	Power supply – (terminal 31)
3	Auxiliary drive
4	Terminal D+
5	W-bus (Webasto Thermo Test Diagnosis connection)
6	K-bus
7	CO2 setting
8	external temperature sensor +
9	external temperature sensor -
10	Setpoint sensor +
11	Setpoint sensor -
12	Input, switch-on signal (ON/OFF)
13	Power supply, control element / error code output
14	Output, vehicle fan relay/output, battery disconnecter afterrunning signal
15	Output, battery disconnecter afterrunning signal/output, vehicle fan relay
16	Input, Ventilate (only for operation with control elements without W-bus)
17	Not used
18	Not used

14 Initial start-up

Carefully bleed the fuel supply system after installing the heater.

NOTE:

Due to the low fuel consumption, it is necessary to switch on the heater several times to fill the fuel line.

Due to the frequent faulty start attempts, the heater may assume fault lock-out mode for safety reasons - see Chapter 15, "Fault switch-off".

Trial run the heater to check all connections for leaks and to make sure they are secure. If the heater encounters a fault during operation, perform the troubleshooting procedure to locate the fault.

15 Fault switch-off

The control unit identifies faults in individual heater components and malfunctions during operation.

The heater shuts down (fault lock-out) when:

- No or faulty start
- Temperature sensor defective
- Overheating sensor interrupted or short-circuited
- Overheating sensor installed incorrectly
- Glow plug interrupted or short-circuited
- Fan motor overload or blocked or short-circuited or interrupted
- Fault in fuel pump electrical circuit or in overheating protection (only during start phase)
- Undervoltage <10.5 V or overvoltage >16 V, longer than 20 s (12V heater)
- Undervoltage <20.5 V or overvoltage >31 V, longer than 20 s (24V heater)
- Control unit defective
- Overheating
- Flame monitor defective (petrol heater)

The fuel supply shuts down in the event of overheating.

The heater continues to run (afterrunning period) as when switched off manually.

The control unit is in fault lock-out at the end of the afterrunning period.

Overheating is indicated by the operating indicator flashing 10 times.

Rectify fault.

Briefly switch the heater on and off (at least 2 seconds) to reset fault lock-out.

The heater will be locked (F 12) if serious malfunctions such as overheating or failure to start occur frequently and can be restarted by disconnecting the power supply **with the heater switched on** (e.g. by removing and reinserting fuse).

15.1. Fault code output

NOTE:

After a fault has occurred in heaters with a control element, the fault code is output by the switch-on indicator/fault code indicator lamp flashing. After 5 fast flash pulses, the fault code is output by a sequence of long flash pulses, corresponding to the numbers in the table below.

After a fault has occurred in heaters equipped with the combination timer, the fault code is shown in the timer display. The fault number is indicated by the indicator lamp flashing if the control element is used:

F 00	Control unit fault / incorrect data set / K-bus faulty
F 01	No start (no flame formation)
F 02	Flame failure (repeated > 3)
F 03	Undervoltage or overvoltage
F 04	Premature flame recognition
F 05	Flame monitor (petrol heater) interrupted or short-circuited
F 06	Temperature sensor interrupted or short-circuited
F 07	Fuel pump interrupted or short-circuited
F 08	Fan motor interrupted or short-circuited or overloaded or blocked
F 09	Glow plug interrupted or short-circuited
F 10	Overheating
F 11	Overheating sensor interrupted or short-circuited
F 12	Heater lock-out
F 14	Overheating sensor incorrect position
F 15	Setpoint sensor interrupted

16 Technical data

Except where limit values are specified, the technical data refer to the usual heater tolerances of $\pm 10\%$ at an ambient temperature of $+20\text{ }^{\circ}\text{C}$ and at the rated voltage and in rated conditions.

16.1. Electrical components:

The control unit, motor, bulb in timer and glow plug/flame monitor are designed for either 12 V or 24 V operation.

The timer, overheating sensor and temperature sensor are not dependent on voltage.

16.2. Fuel for Air Top 2000 STC B (petrol):

The fuel specified by the vehicle manufacturer must be used.

16.3. Fuel for Air Top 2000 STC D (diesel/fuel oil EL):

The diesel fuel in accordance with DIN EN590 specified by the vehicle manufacturer must be used. If it complies with the normal quality available in the German market as per DIN 51603, Class EL fuel oil (not L fuel oil) can also be used.

There are no known adverse effects of using additives.

If fuel is taken from the vehicle's fuel tank, follow the additive instructions issued by the vehicle manufacturer.

When changing to low-temperature fuel, the heater must be operated for approx. 15 minutes to fill the fuel system with the new fuel.

The Air Top 2000 STC D heaters are also approved for use with biodiesel (FAME) conforming to DIN EN 14214.

Air Top 2000 STC

Technical data

Heater	Operation	Air Top 2000 STC B	Air Top 2000 STC D
Type approval	EMC Heater	E1 R10- 04 1085 E1 R122- 00 0216	
Design		Air heater with evaporator burner	
Heat flow	Control range	1.0 - 2.0 kW	0.9 - 2.0 kW
Fuel		Petrol EN 228 DIN 51625	Diesel/FAME EN 590 DIN 51603 DIN EN 14214
Fuel consumption	Control range	0.1 - 0.2 kg/h (0.14 - 0.27 l/h)	0.1 - 0.21 kg/h (0.12 - 0.24 l/h)
Rated voltage		12 Volt	12 / 24 Volt
Operating voltage range		10.5 - 16 Volt	10.5 - 16 / 20.5 - 31 Volt
Rated power consumption	Control range	14-29 W	
Permissible ambient temperature: Heater: - Operation - Storage		-40 to + 40 °C -40 to + 85 °C	
Fuel pump: - Operation - Storage		-40 to + 20 °C -40 to + 85 °C	
Control element: - Operation - Storage		-40 to + 75 °C -40 to + 85 °C	
Permissible combustion air intake temperature		-40 to + 20 °C	
Adjustment range for interior temperature	Control range	+5 to + 35 °C	
Volumetric flow of hot air at fan speed	at 0.5 mbar	max. 93 m ³ /h at 4750 rpm	
CO ₂ in exhaust gas (permitted function range)	1 kW 2 kW	5.0 - 8.0 % 9.0 - 12.5 %	5.0 ... 8.0 % 9.0 ... 12.5 %
Heater dimensions		Length 311 ± 2 mm Width 120 ± 1 mm Height 121 ± 1 mm	
Weight		2.6 kg	

17 Variants

Air Top 2000 STC B (petrol)

Air heater for petrol (12 V)

Air Top 2000 STC D (Diesel)

Air heater for diesel/fuel oil EL (12 or 24 V)

Air Top 2000 STC

Drilling template

18 Drilling template

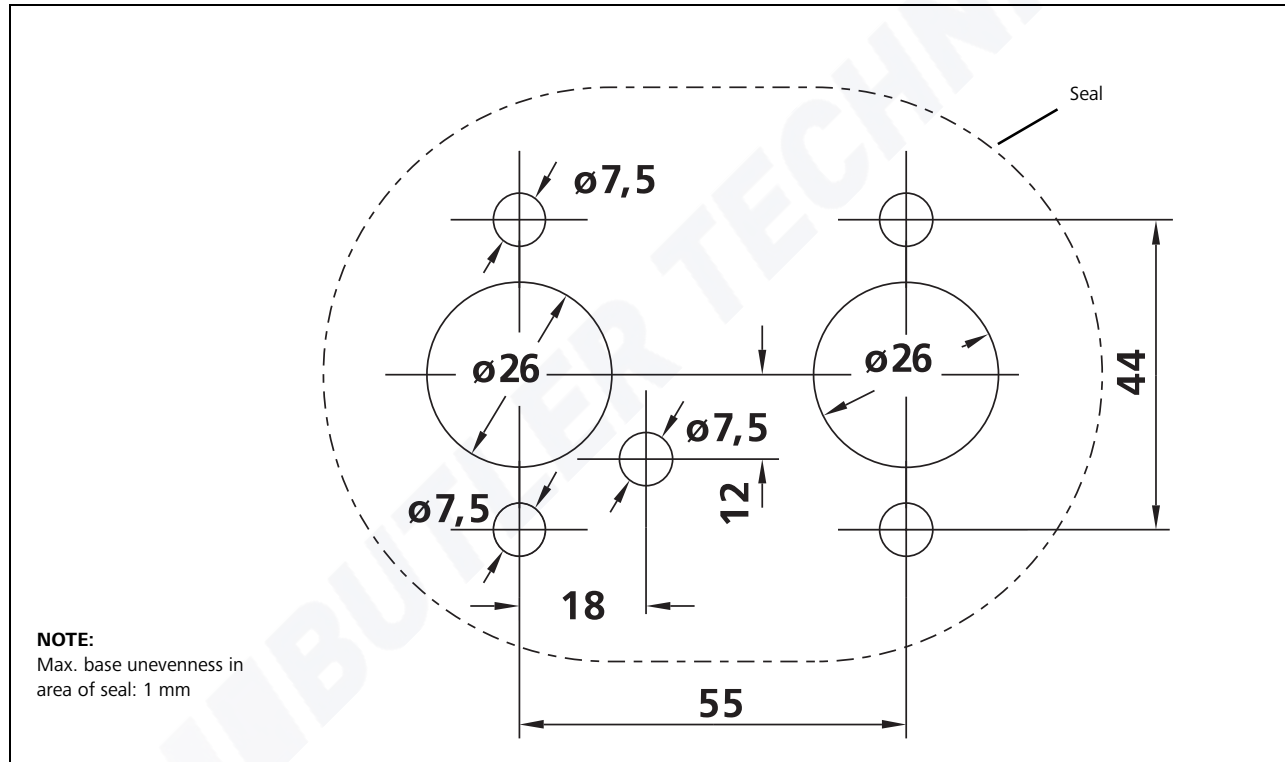

Fig. 33: Drilling template

Im Fall einer mehrsprachigen Version ist Deutsch verbindlich.

Die Telefonnummer des jeweiligen Landes entnehmen Sie bitte dem Webasto Servicestellenfaltblatt oder der Webseite Ihrer jeweiligen Webasto-Landesvertretung.

In multilingual versions the German language is binding.

The telephone number of each country can be found in the Webasto service center leaflet or the website of the respective Webasto representative of your country.

En cas de version multilingue, c'est la langue allemande qui fait foi.

Pour trouver le numéro de téléphone du pays concerné, veuillez consulter le dépliant des points-service Webasto ou la page web de la représentation Webasto de votre pays.

Webasto Thermo & Comfort SE
Postfach 1410
82199 Gilching
Germany

Besucheradresse:
Friedrichshafener Str. 9
82205 Gilching
Germany

Technical Extranet: <http://dealers.webasto.com>

Nur innerhalb von Deutschland
Tel: 0395 5592 444
E-mail: technikcenter@webasto.com