

U-PROFILE & L-PROFILE INSTALLATION GUIDE

Please check if your rear lights are suitable for this replacement. If you do not have the current split light but the previous one-piece version of lights, you will need to purchase **1x HCSP00928** Rear Light Modification Kit and for region **EU, AUS, NZ** and **2x HCSP00407** Rear lights. For the region **US** **2 x HCSP00408** Rear lights. More information and manuals are available on our homepage www.herocamper.com under each spare part number. Please note this guide is used for both part numbers: **HCSP00395** - HeroCamper U Profile Mat Black Aluminum Both Sides and **HCSP00400** - HeroCamper L Profile Mat Black for Both Sides

COMPONENTS

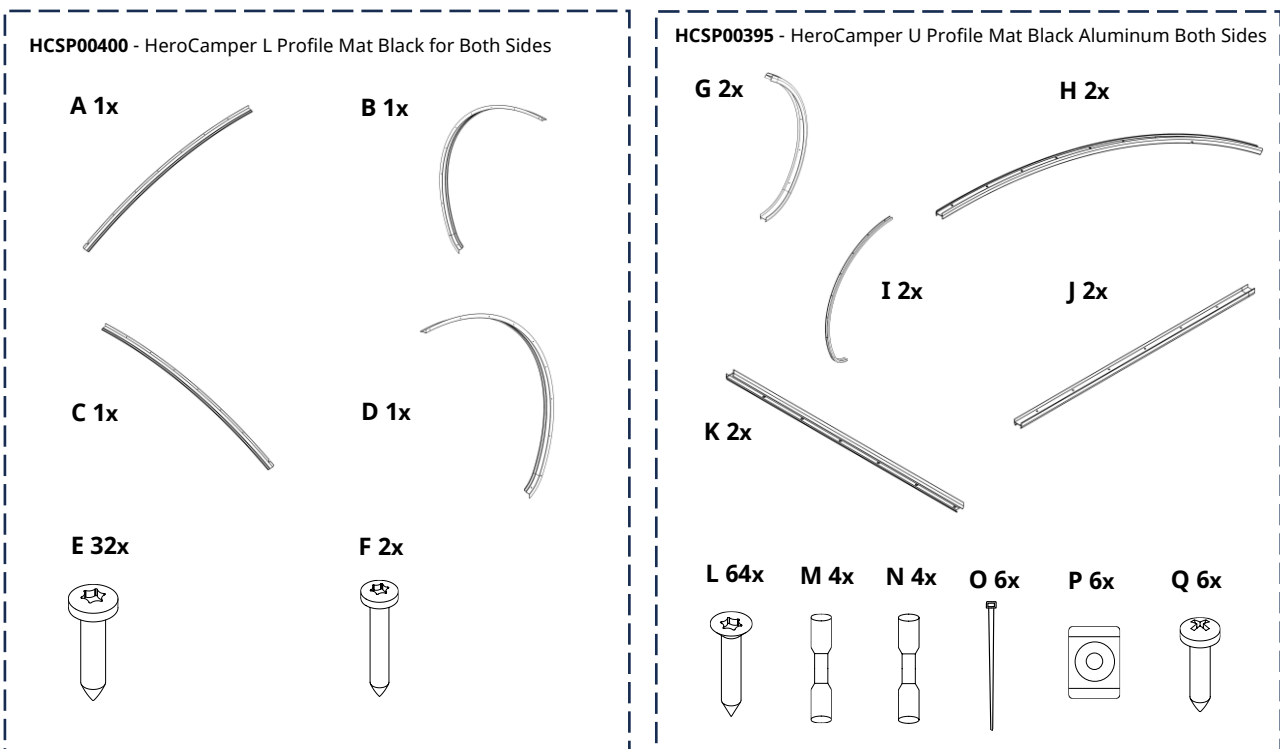

A: Left L-profile 1 **B:** Left L-profile 2 **C:** Right L-profile 1 **D:** Right L-profile 2 **E:** Black TX 20 ST4.2x19
F: Pan Black TX 20 ST4.8x32 **G:** U-profile 1 **H:** U-profile 2 **I:** U-profile 3 **J:** U-Profile 4 **K:** U-Profile 5
L: Countersunk ST4.8x32 **M:** Blue Cold-pressed Terminal **N:** Pink Cold-pressed Terminal **O:** Zip-tie
P: Zip-tie holder **Q:** PH Pan head screw ST3.5x16

TOOLS FOR INSTALLATION



INSTALLATION GUIDE

1. This guide will show step by step for one side. The process is the same on the opposite side. Unmount the U-rubber profile all the way around and put it aside.

Note: If it not going to be reused, please discard it. If needed to be replaced the part number for Black Rubber for U-profile is HCSP00675.

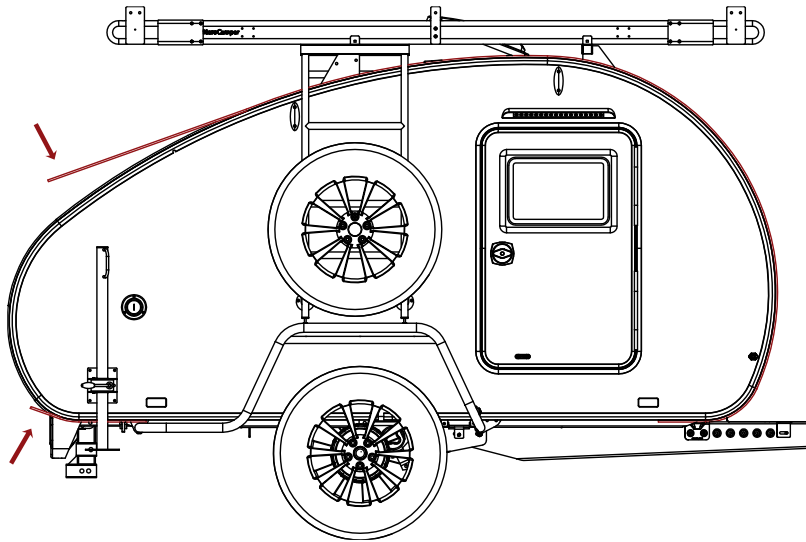

2. Note: If you have the previous one-piece lights, please read the installation guide for **HCSP00928** Rear Light Modification Kit before you continue.
Unscrew the 4xPH screws in the top and bottom of the rear lights.

3. Slide the top light upwards to release it and the bottom light downwards. Disconnect the multiplugs and put the lights aside.

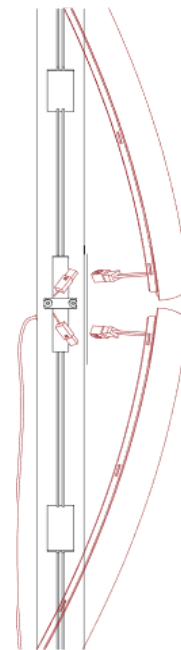
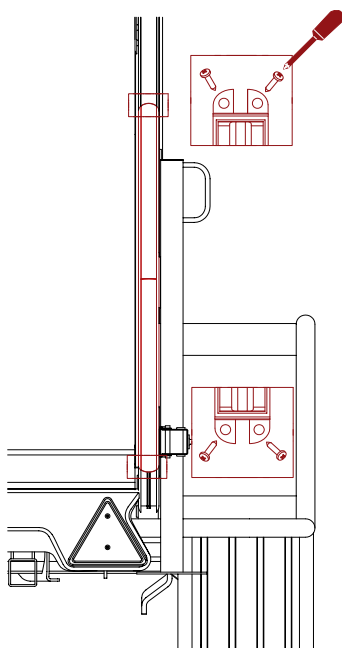

4. Unmount the bracket for the lights and put them aside.

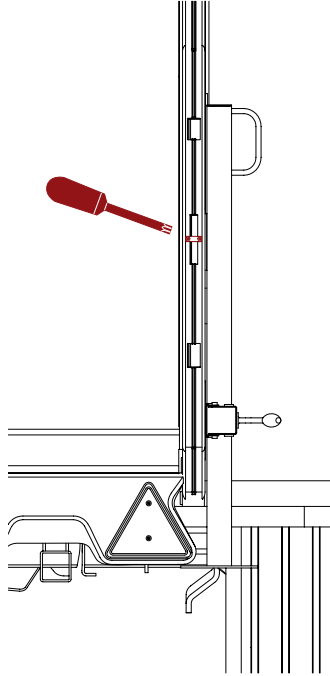

5. Cut the wires for clearance lamps on both sides of the terminals.

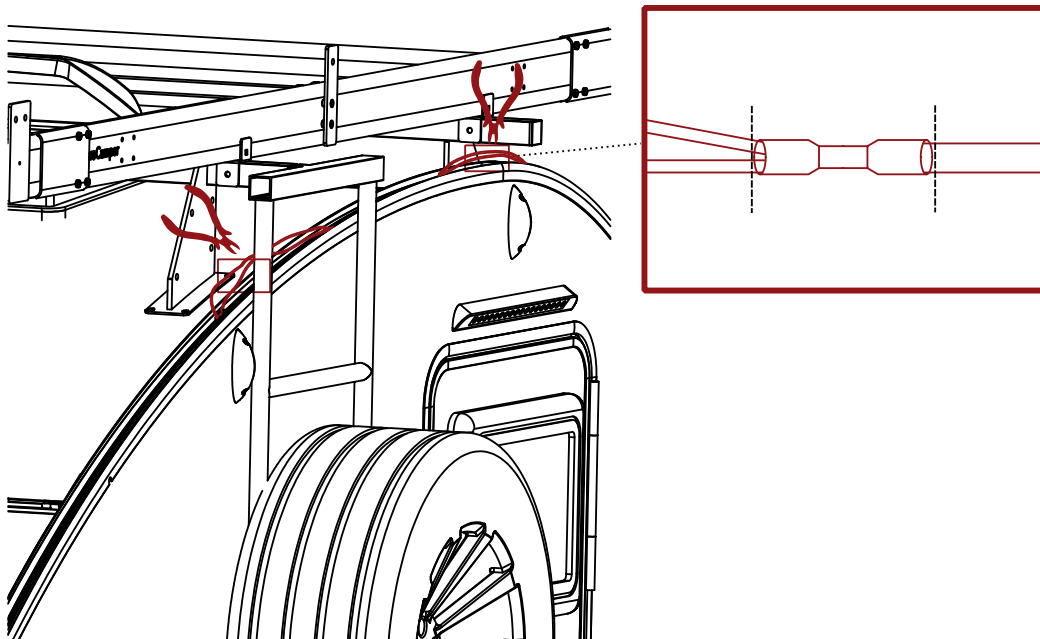

6. Unmount the wire brackets underneath the camper located inside the U-Profile.

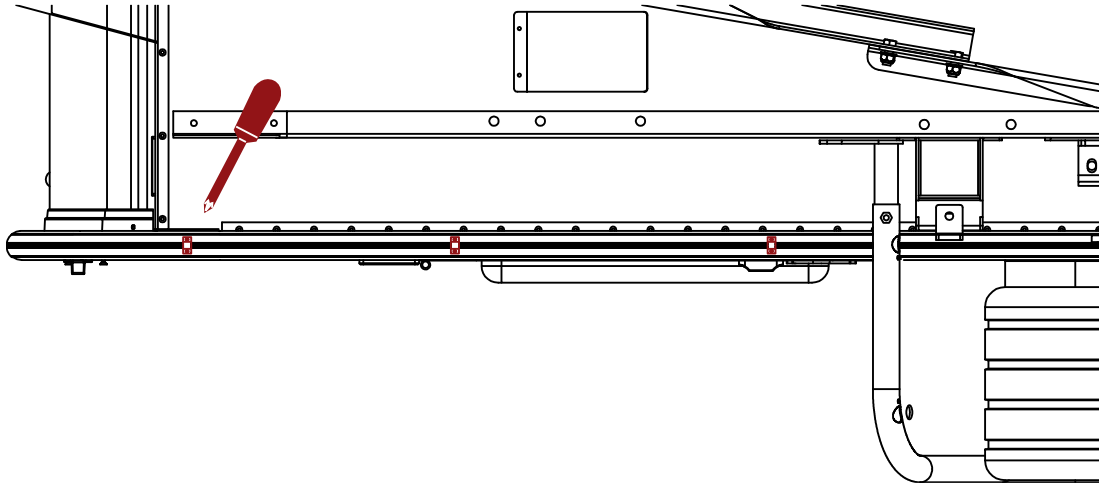

7. Unscrew all screws inside the U-profile and unmount the U-profile.
If you only replacing the U-profile, please jump to Step 15.

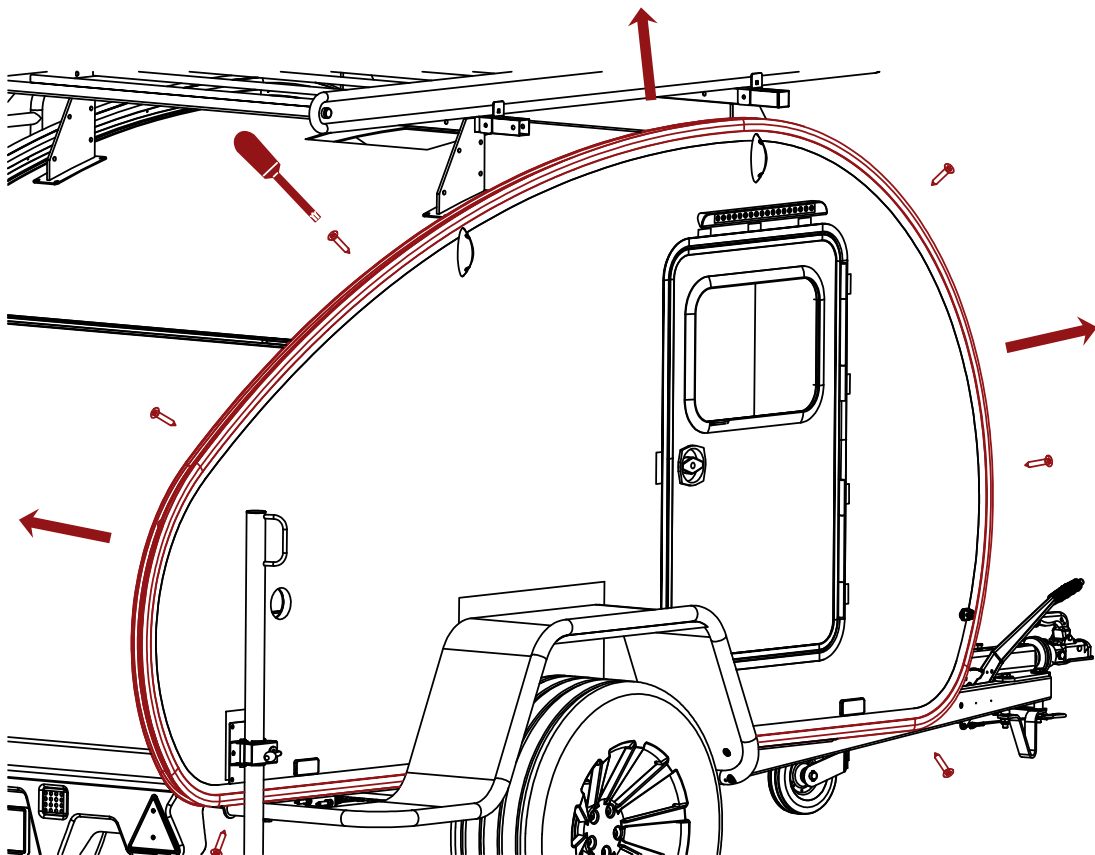

8. Remove the Rain Cover and put it aside.

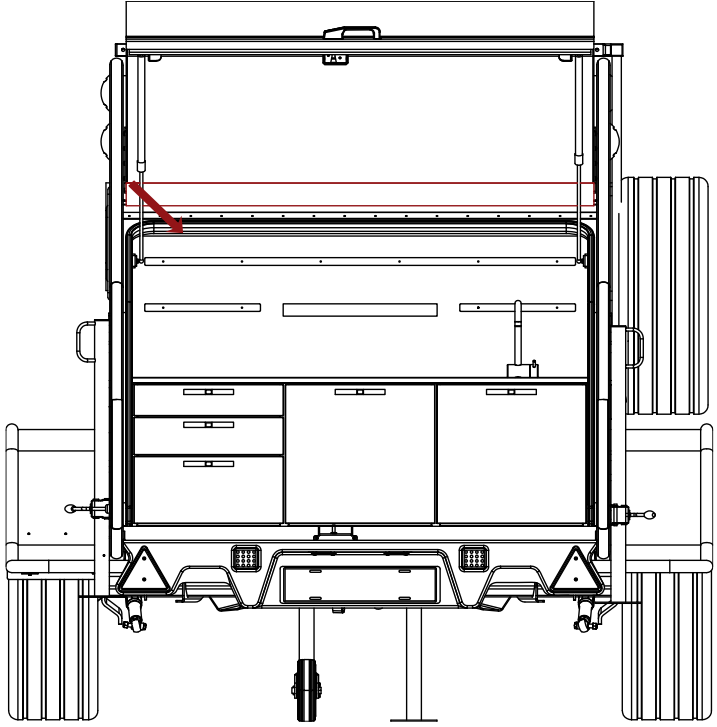

9. **WARNING:** Please make sure 2-3 person or approved lifting equipment that fits this procedure. The rear door will fall when gas damper is removed. Use M13 and M12 wrench to unmount the gas spring and keep the nuts for later.

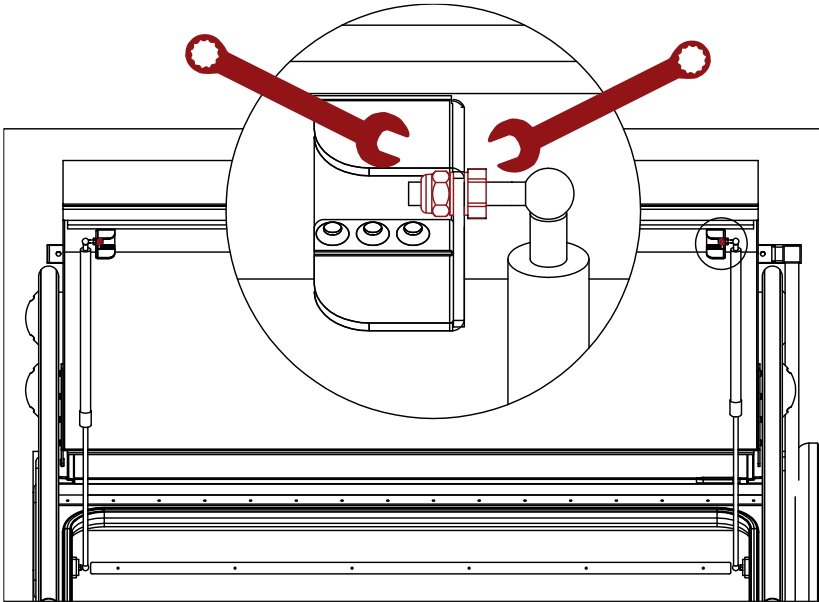

10. WARNING: Please make sure 2-3 person or approved lifting equipment that fits this procedure. The rear door will be detached when the bolts is removed. Unscrew the bolt on both sides with a M8 hex key.

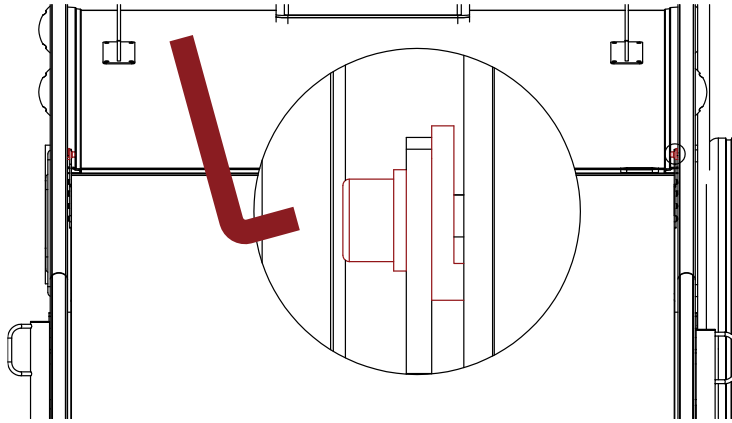

11. Unmount the screws on the L-profile. Unmount the L-profile and discard it.

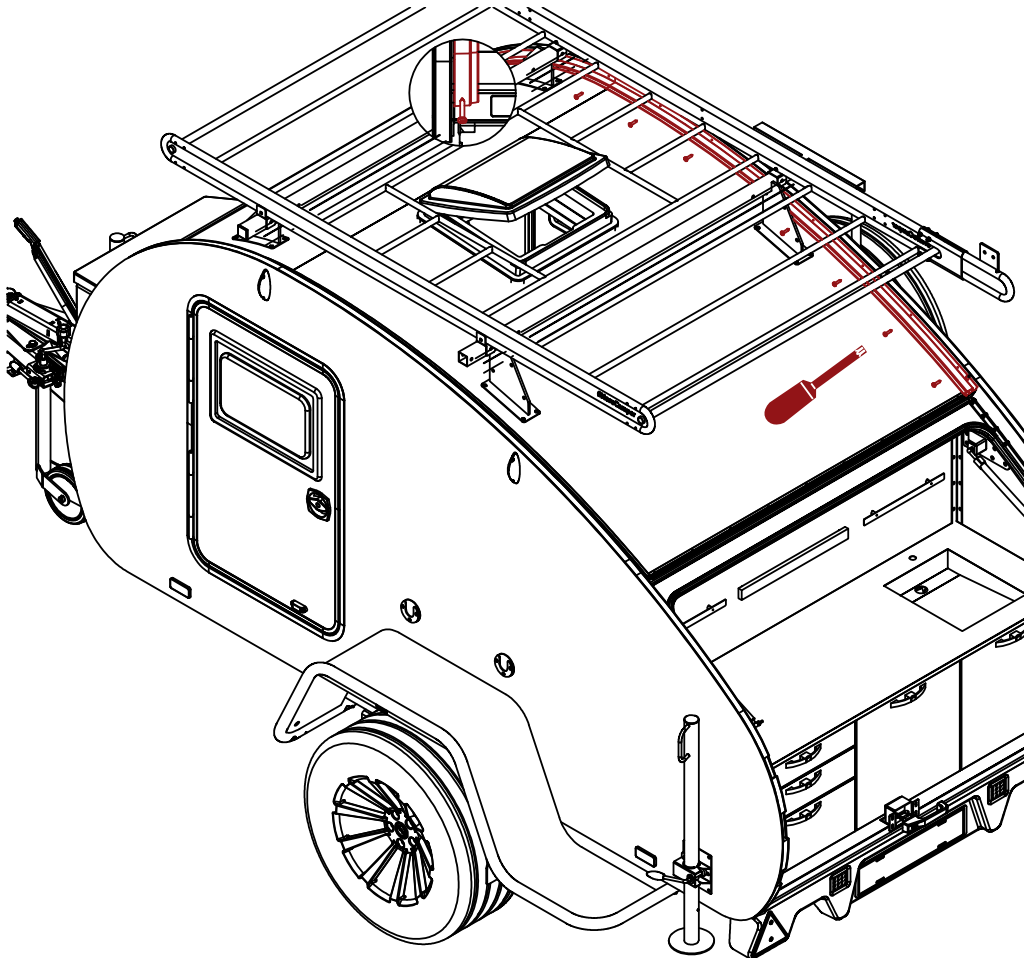

12. Mount the new L-profile. (Part used: C, D, E and F)

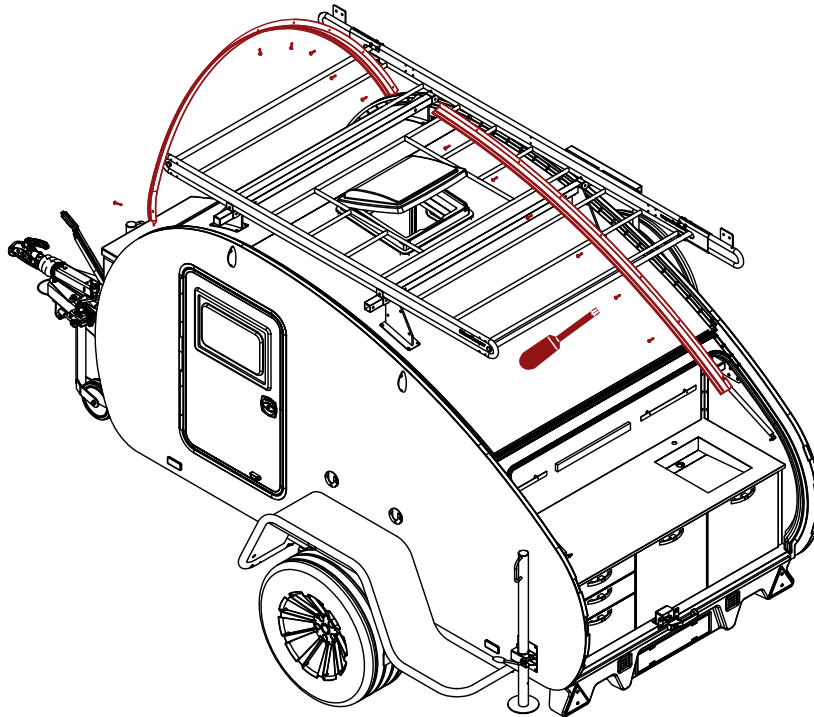

13. **WARNING:** Please make sure 2-3 person or approved lifting equipment that fits this procedure. Remount the rear door with the M8 hex key. Recommended torque is 14Nm.

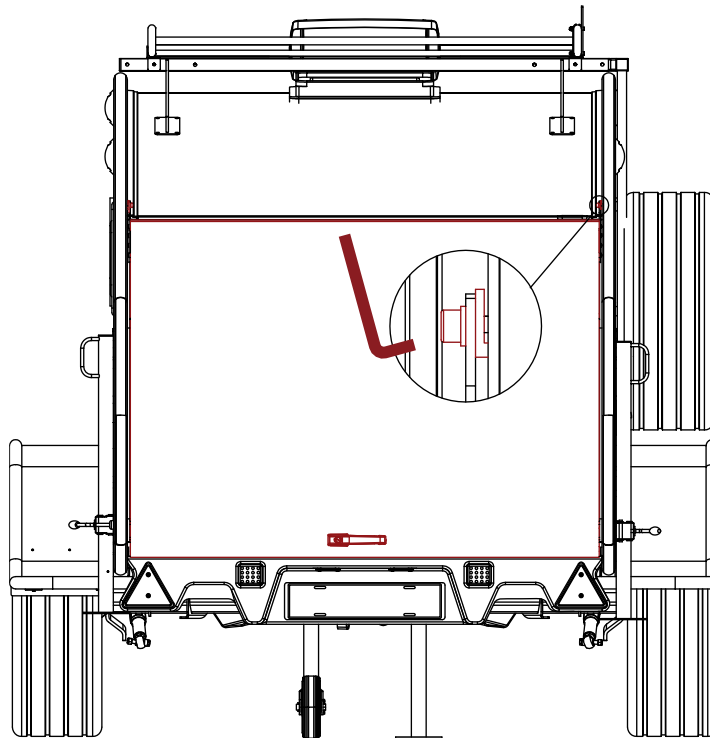

- 14. WARNING:** Please make sure 2-3 person or approved lifting equipment that fits this procedure. The rear door will drop when gas springs are unmounted. Use M13 and M12 wrench to remount the gas springs. Recommended torque is 20Nm. If you need to adjust the door lock afterwards, please check our FAQ here for guidance: <https://herocamper.com/faq/>

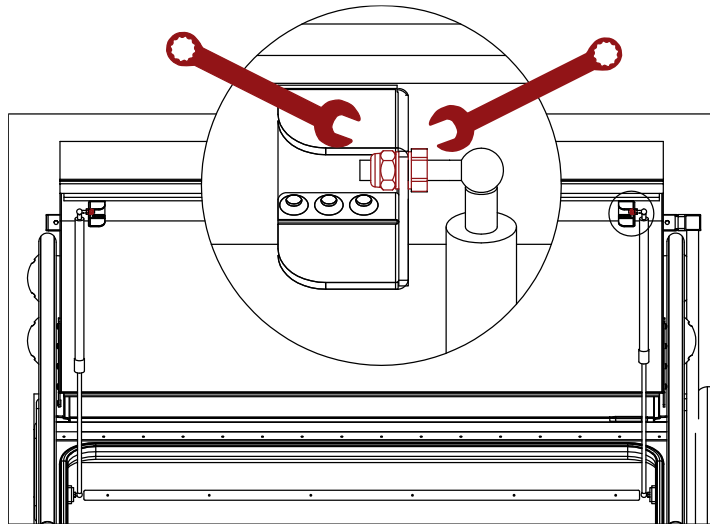

- 15. Mount the new U-profiles.** (Parts used: G, H, I, J, K and L)

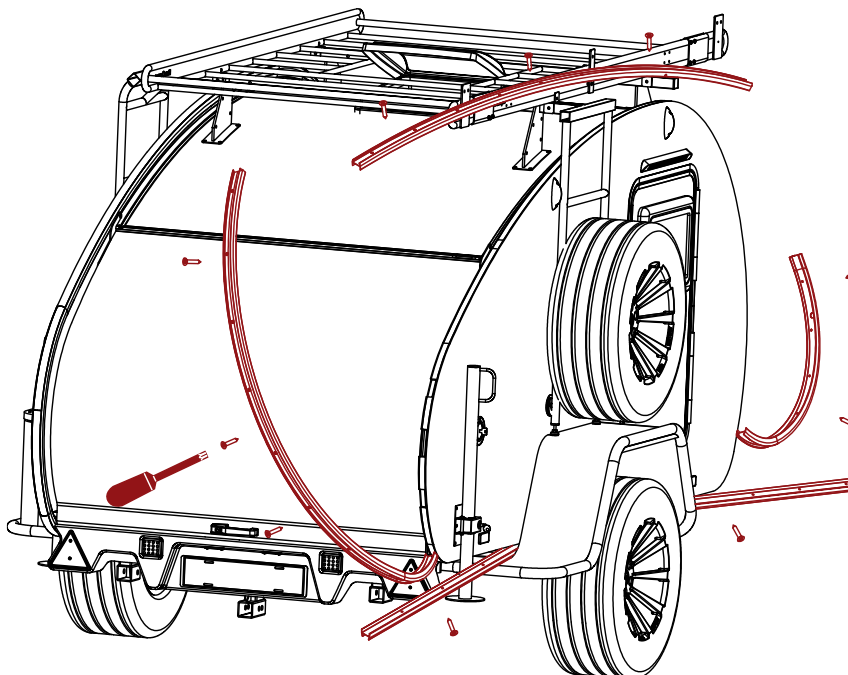

16. Gently slide the lights into the U-profile. The upper light should be the 3 pins and lower light the 2 pins.

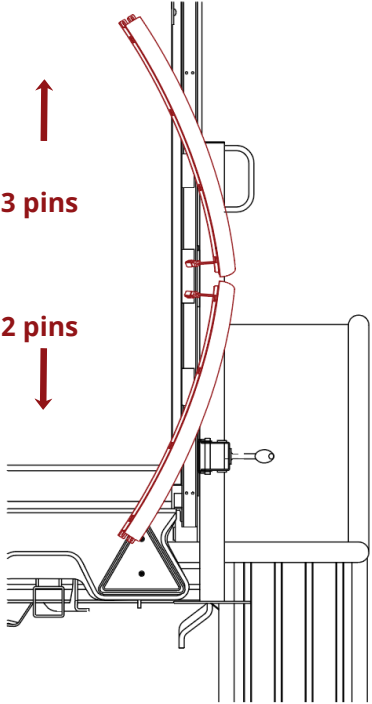

17. Mount the Zip-tie holders inside the U-profile. Fix the wire with zip-tie. (Part used: O, P and Q)

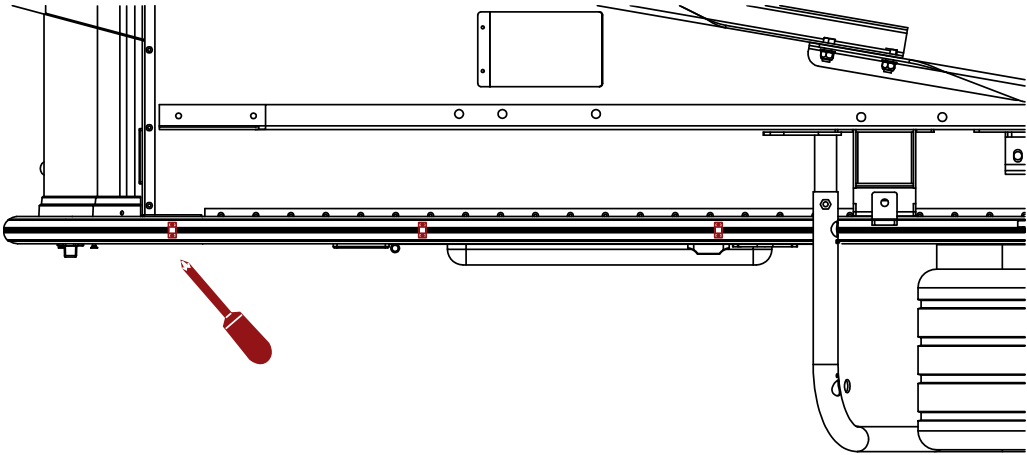

18. Strip off the wires for the clearance lamps.

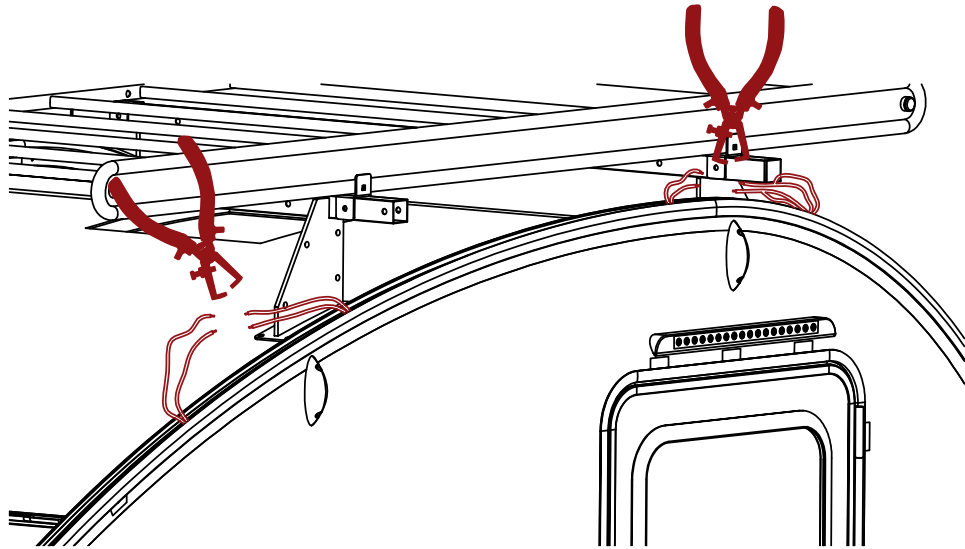

19. Connect the wires with Cold-pressed Terminals.

Front: Use the Blue Terminals and connect 2x black wires to 1x black wire. 2x white wires to 1x white wire.

Rear: Use the Pink Terminals and connect 1x black wire to 1x black wire. 1x white wires to 1x white. (Parts used: M and N)

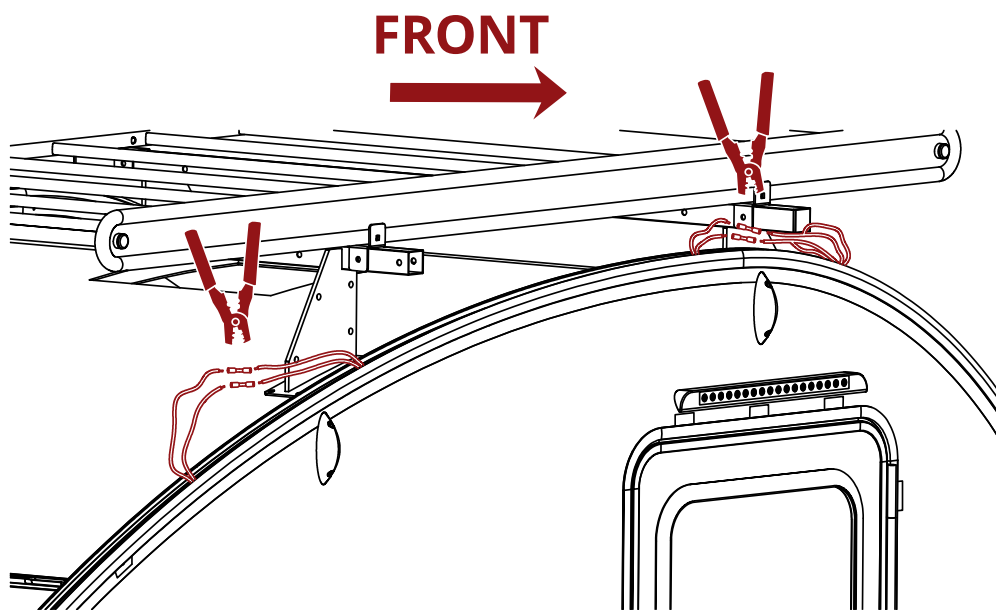

20. Remount the U-rubber profile all the way around.

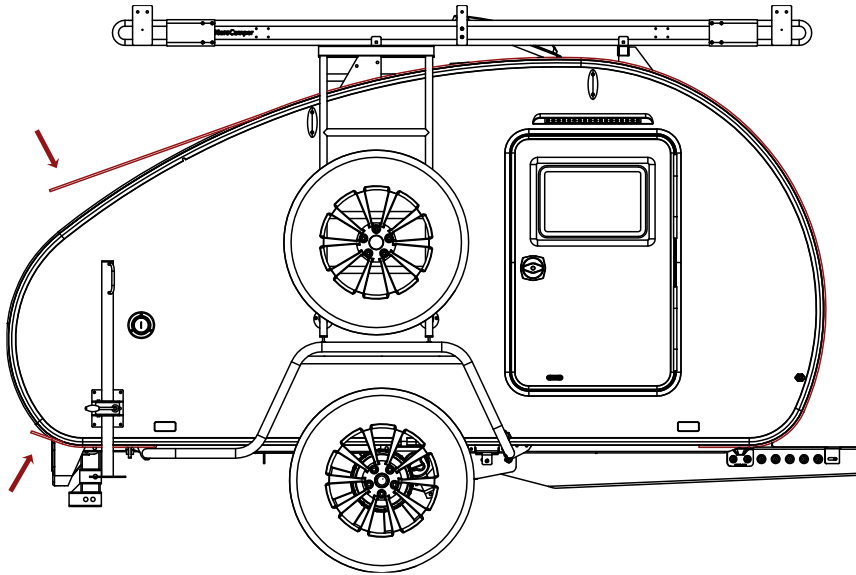

All products that are not mounted by an authorized HeroCamper dealer are at your own risk!